

Data Collection, Review and Flood Study for West Coonamble, Gulargambone and Quambone

COONAMBLE SHIRE COUNCIL

Quambone Flood Study Report

FINAL

October 2016



JACOBS®

Quambone Flood Study Report

Project no: IA013100/EN04190
 Document title: Quambone Flood Study Report
 Document no: Document No.
 Revision: FINAL
 Date: October 2016
 Client name: Coonamble Shire Council
 Client no:
 Project manager: Akhter Hossain
 Author: Michael Reeves/ Akhter Hossain
 File name: I:\ENVR\Projects\EN04190\Deliverables\Reports\Quambone\Final Report\Quambone Flood Study_Final Report.docx

Jacobs Group (Australia) Pty Limited
 ABN 37 001 024 095
 100 Christie Street
 St Leonards NSW 2065 Australia
 PO Box 164 St Leonards NSW 2065 Australia
 T +61 2 9928 2100
 F +61 2 9928 2500
 www.jacobs.com

COPYRIGHT: The concepts and information contained in this document are the property of Jacobs Group (Australia) Pty Limited. Use or copying of this document in whole or in part without the written permission of Jacobs constitutes an infringement of copyright.

Document history and status

Revision	Date	Description	By	Review	Approved
1	5/11/2014	Draft	MR, AH	J Wall	J Wall
2	24/3/2016	Draft Final Report	AH	AH	AH
3	23/5/2016	Draft Final Report (updated)	AH	AH	AH
4	26/10/2016	Final Report	AH	A Hossain	A Hossain

Contents

Foreword	1
1. Introduction	3
1.1 Objectives	3
1.2 Structure of the Report	5
2. Initial Investigations	6
2.2.1 Available Reports	6
2.2.2 Flood Planning and Development Control Plans	8
2.2.3 Rainfall Data	9
2.3 Community Consultation	10
2.3.1 Flood Questionnaire	10
2.3.2 Summary of Responses to Flood Questionnaire	10
2.4 Topographic Survey	11
2.4.1 LiDAR Survey	11
2.4.2 Ground Survey	11
3. Catchment Hydrology	13
3.1 Sources of Flooding	13
3.2 Catchment Description	13
3.3 Estimation of Design Discharges	13
3.3.1 Selection of the Rainfall Runoff Model	13
3.3.2 Configuration of the RORB Model	13
3.3.3 Input Data for Design Flood Estimation	14
3.4 Design Discharges	15
4. Hydraulic Modelling	16
4.1 Approach	16
4.2 The Hydrodynamic Modelling Software	16
4.3 Model Formulation	16
4.3.1 Schematisation	16
4.3.2 Manning's 'n'	17
4.3.3 Boundary Conditions	18
4.4 Flood Behaviour	18
4.5 Sensitivity Analysis	19
4.6 Flood Extent Mapping	20
4.7 Mapping of Hazard and Hydraulic Categories	20
5. Conclusions and Recommendations	24
5.1 Conclusions	24
5.2 Recommendations	24
6. Acknowledgements	26
7. References	27
8. Glossary	28

Appendix A. Questionnaire

Appendix B. Topographic Survey

Appendix C. Hydrologic Modelling

Appendix D. Hydraulic Modelling

Foreword

The primary objective of the New South Wales Government's Flood Prone Land Policy is to reduce the impact of flooding and flood liability on individual owners and occupiers of flood prone property, and to reduce private and public losses resulting from floods, utilising ecologically positive methods, wherever possible. Under the Policy, the management of flood prone land remains the responsibility of local government.

The policy provides for a floodplain management system comprising the following five sequential stages:

- 1. Data Collection** Involves compilation of existing data and collection of additional data
- 2. Flood Study** Determines the nature and extent of the flood problem
- 3. Floodplain Risk Management Study** Evaluates management options in consideration of social, ecological and economic factors relating to flood risk with respect to both existing and future development
- 4. Floodplain Risk Management Plan** Involves formal adoption by Council of a plan of management for the floodplain
- 5. Implementation of the Plan** Implementation of flood, response and property modification measures (including mitigation works, planning controls, flood warnings, flood preparedness, environmental rehabilitation, ongoing data collection and monitoring by Council)

Coonamble Shire Council intends to develop a Floodplain Risk Management Plan for the Village of Quambone to address the existing, future and continuing flood problems, in accordance with the NSW Floodplain Development Manual (2005). This report represents the first and the second stages of the management process and has been prepared for Council by Jacobs (Sinclair Knight Merz merged with Jacobs in December 2013). It documents the nature and flooding extents within the Study Area for Quambone and is an essential resource for the subsequent stages of the floodplain management process.

Important note about this report

The sole purpose of this report and the associated services performed by Jacobs is to prepare a flood study report for the village of Quambone in accordance with the scope of services set out in the contract between Jacobs and Coonamble Shire Council (hereafter Council). That scope of services, as described in this report, was developed with the Council.

In preparing this report, Jacobs has relied upon, and presumed accurate, any information (or confirmation of the absence thereof) provided by the Council and/or from other sources. Except as otherwise stated in the report, Jacobs has not attempted to verify the accuracy or completeness of any such information. If the information is subsequently determined to be false, inaccurate or incomplete then it is possible that our observations and conclusions as expressed in this report may change.

Jacobs derived the data in this report from information sourced from the Council (if any) and/or available in the public domain at the time or times outlined in this report. The passage of time, manifestation of latent conditions or impacts of future events may require further examination of the project and subsequent data analysis, and re-evaluation of the data, findings, observations and conclusions expressed in this report. Jacobs has prepared this report in accordance with the usual care and thoroughness of the consulting profession, for the sole purpose described above and by reference to applicable standards, guidelines, procedures and practices at the date of issue of this report. For the reasons outlined above, however, no other warranty or guarantee, whether expressed or implied, is made as to the data, observations and findings expressed in this report, to the extent permitted by law.

This report should be read in full and no excerpts are to be taken as representative of the findings. No responsibility is accepted by Jacobs for use of any part of this report in any other context.

All topographic data used in this study were sourced from a LiDAR survey and a ground survey which were undertaken by third parties. Undertaking independent checks on the accuracy of the topographic data was outside Jacobs' scope of work for this study.

This report has been prepared on behalf of, and for the exclusive use of, Council, and is subject to, and issued in accordance with, the provisions of the contract between Jacobs and Council. Jacobs accepts no liability or responsibility whatsoever for, or in respect of, any use of, or reliance upon, this report by any third party.

1. Introduction

Quambone (population 247 and 50 dwellings) is located approximately 55 km west of Coonamble, in the central west of NSW. The Village of Quambone, declared on 28 July 1894, was developed on Quambone Station. Quambone is the gateway to the Macquarie Marshes and the village has two bush churches, tennis courts, a swimming pool, the smallest operational library in NSW and a two teacher school (<http://www.coonambleshire.nsw.gov.au/VisitingCoonamble/quambone.html>).

The study area for Quambone (refer **Figure 1-1**), shows that the central village area is a typical grid pattern running in a north-south and east-west direction. Merri Merri Creek runs along the western side of the village and drains a catchment area of approximately 1,330 km² near the village.

The village has experienced in excess of 12 flood events since 1950 with creek and local overland flows causing flooding in low lying areas. Hence, there is a need to define the extent of flooding and to determine appropriate development controls and flood risk management plans for the village.

Sinclair Knight Merz (operating as Jacobs since December 2013) was engaged by Coonamble Shire Council in May 2013 to undertake a flood study for the study area in Quambone.

1.1 Objectives

Objectives of this study are to:

- Define the extent of flooding within Quambone and to highlight problem areas for a range of flood events;
- Determine the potential impact of overland flooding;
- Identify development controls to minimise any future impact on private and public assets; and
- Prepare a flood planning area map for inclusion into the Coonamble LGA - LEP 2011.

The overall study is being undertaken in two major phases:

Stage 1 Initial Investigations

- Undertake a comprehensive site inspection with nominated Council staff, authorised representatives and nominated local residents as arranged by Council.
- Review of all relevant documents, data and available reports.
- Undertake a comprehensive consultation with the local community, Council and relevant agencies.
- Collate and assess all data and information required to satisfy the objectives.
- Identify any gaps in the available data including surveys required to complete the study and update all information as required with the approval of the Council.

Stage 2 Flood Study

- Establish appropriate hydrologic and hydraulic/ hydrodynamic models to include riverine and overland flooding for the village of Quambone for use in the estimation of design floods. The events of interest include the 0.5%, 1% and 5 % annual exceedance probability (AEP) events, together with the Probable Maximum Flood (PMF) / or relevant extreme flood event.
- Following the above, establish appropriate hydraulic hazard categories including floodways, flood storages, flood fringes, etc. along with the mapping of the Flood Planning Area for residential developments (1% event flood level+ 0.5 m freeboard – considered to be the flood planning level for residential development) as described in Planning Directions for NSW.
- Propose recommendations for development controls as a management measure in the Floodplain Risk Management process for the Village of Quambone.



Legend

- Study Area
- Cadastre
- Daily Read Rain Gauge
- ▲ Stream Gauge
- Water Course

SCALE		A3	
SHEET		1 of 1	
		GDA 1994 MGA Zone 55	
TITLE Study Area			
PROJECT Flood Study for Quambone			
CLIENT Coonamble Shire Council			
DRAWN	PROJECT #	MAP #	REV VER
AH	EN04190	FIGURE 1-1	2 1
CHECK	DATE		
AH	8/02/2016		

Data Sources: LPI, Council.

COPYRIGHT: The concepts and information contained in this document are the intellectual property of Jacobs. Use or copying of the document in whole or in part without written permission of Jacobs constitutes an infringement of copyright.

1.2 Structure of the Report

This report describes the outcomes from Quambone Flood Study. This report has been divided into the following sections:

Section 1: introduces the study

Section 2: provides details on the initial investigations undertaken for the study including review of the available data and community consultation

Section 3: details hydrologic assessment undertaken for this study

Section 4: details hydraulic assessment, flood behaviour and flood mapping

Section 5: provides conclusions and recommendations on the study

Section 6: provides acknowledgements for this study

Section 7: provides details on references cited in this report

Section 8: provides the glossary of terms

Appendix A: contains the Newsletter and Questionnaire sent to residents

Appendix B: provides topographic survey details

Appendix C: details on hydrologic modelling

Appendix D: details on hydraulic modelling

2. Initial Investigations

2.1 Site Inspection

A site inspection was carried out on 5 June 2013 to gain an overall appreciation of the study area, including flood behaviour. During the site inspection, residents explained that almost the entire village was flooded during the flood event of 1955. Information gained from the site reconnaissance was utilised to define the scope of the topographic survey for this study and to determine modelling parameters such as Manning's roughness coefficients for channels and floodplains located within the study area.

2.2 Data Collection and Review

Council and a number of government agencies including NSW Office of Environment and Heritage (OEH), NSW Department of Primary Industries (DPI) Water, State Emergency Services (SES) and the Bureau of Meteorology, were contacted to collect information on flooding, topographic data and flood evacuation etc. However, very limited information was available from the agencies.

2.2.1 Available Reports

- **Coonamble Shire Flood Emergency Sub Plan (2013)** – The plan covers preparedness measures, the conduct of response operations and the coordination of immediate recovery measures from flooding within the Coonamble Shire Council area. The plan covers all levels of flooding within the Council area. The plan does not include any flood intelligence. The plan identifies that the following locations may be suitable for use as flood evacuation centres in Quambone:
 - Public School, Mungie Street;
 - Memorial Hall, Mungie Street; and
 - Medical Centre.
- **Quambone, A Village of 100 Years, 1894-1994 edited by J Andrews, V Wild and C Fisher (1994)** – The booklet was compiled to mark the centenary of the village which was declared on 28 July 1894 and provides details on the past and present developments located within the village. It also shows photographs of the 1955 flood at T R Sinclair store (refer **Figure 2-1**) and moving the “Plonk Shop” (refer **Figure 2-2**). The “Plonk Shop” was located on the western side of Tucca Tucca Street, three blocks from Gilgunnia Street. The booklet identifies that a storm in 1928 took the Quambone Memorial Hall roof off.
- **Macquarie Valley Flood Plain Atlas (SKP 1984)** – The Atlas covers the majority of the catchment area of the Macquarie River Valley. The extent of flooding shown in the Atlas largely represents that of 1955 flood, which is the largest flood on record in the catchment. The information presented in the Atlas was prepared from interviews with landholders and Local Government Authorities and records of the Water Resources Commission and local offices of other statutory authorities. An extract from the photomap “Quambone-South” is shown in **Figure 2-3** which indicates that extensive flooding west of Tucca Tucca Street and flooding in water courses from local runoff up to one kilometre wide with dry ridges in between along east of Tucca Tucca Street. This means that the majority of the study area was subject to widespread flooding during the 1955 flood event due to local catchment runoff. Further details on the flood behaviour in terms of timing and are duration of not provided in the Atlas.

Figure 2-1 1955 Flood at T R Sinclair Store



Figure 2-2 Moving the "Plonk Shop" during 1955 Flood



Figure 2-3 1955 Flood Extent in Quambone

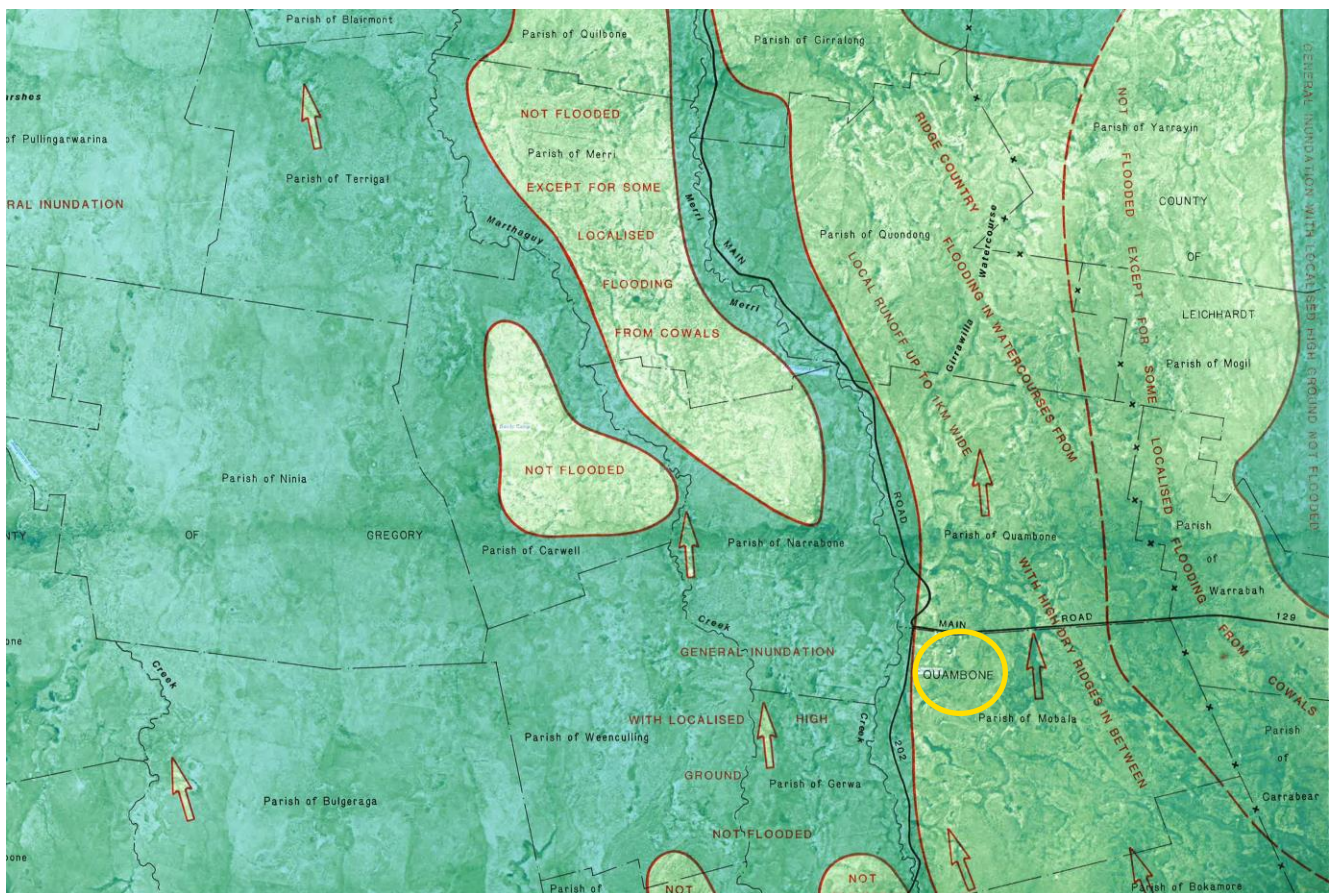

2.2.2 Flood Planning and Development Control Plans

- **Clause 6.6 of Coonamble Local Environment Plan (LEP, 2011)**
 - 1) The objectives of this clause are as follows:
 - to minimise the flood risk to life and property associated with the use of land,
 - to allow development on land that is compatible with the land's flood hazard, taking into account projected changes as a result of climate change,
 - to avoid significant adverse impacts on flood behaviour and the environment.
 - 2) This clause applies to land at or below the flood planning level.
 - 3) Development consent must not be granted to development on land to which this clause applies unless the consent authority is satisfied that the development:
 - is compatible with the flood hazard of the land, and
 - is not likely to significantly adversely affect flood behaviour resulting in detrimental increases in the potential flood affectation of other development or properties, and
 - incorporates appropriate measures to manage risk to life from flood, and
 - is not likely to significantly adversely affect the environment or cause avoidable erosion, siltation, destruction of riparian vegetation or a reduction in the stability of river banks or watercourses, and
 - is not likely to result in unsustainable social and economic costs to the community as a consequence of flooding.

- 4) A word or expression used in this clause has the same meaning as it has in the Floodplain Development Manual (ISBN 0 7347 5476 0), published in 2005 by the NSW Government, unless it is otherwise defined in this clause.
- 5) In this clause, flood planning level means the level of a 1:100 ARI (average recurrent interval) flood event plus 0.5 metre freeboard.

- **Fencing Policy (1999):** The current fencing policy applies to the village of Quambone. The policy does not consider impact of fencing on flood behaviour.
- **Section 149 Certificate:** Coonamble Shire Council issues Section 149 (2) Planning Certificate and Section 149 (2) & (5) Planning Certificate. Information on flood risk is not included on in these Certificates.

2.2.3 Rainfall Data

A search was conducted on the Bureau of Meteorology's website to locate rainfall stations in the close proximity of Quambone Village. The daily read rain gauge located (refer to **Figure 1-1**) at Quambone Station (No. 051042) is the nearest rainfall gauge, located approximately 500m north of the village. The gauge was commissioned in 1900 and it is still in operation.

The twenty (20) highest one-day (9 am to 9 am) rainfall events recorded at rain gauge No. 051042 are shown in **Figure 2-4**. This shows that the maximum one-day rainfall recorded at the gauge was 130mm, which occurred on 8 January 1974, and the second highest rainfall (126mm) occurred on 22 December 2007. The gauge recorded 31mm, 78.5mm and 30.2mm of rainfall on 23, 24 and 25 February 1955, respectively, which is considered the highest flood on record in the village.

Figure 2-4 Twenty Highest 1-Day Rainfall Recorded at Quambone Station Rain Gauge (051042)

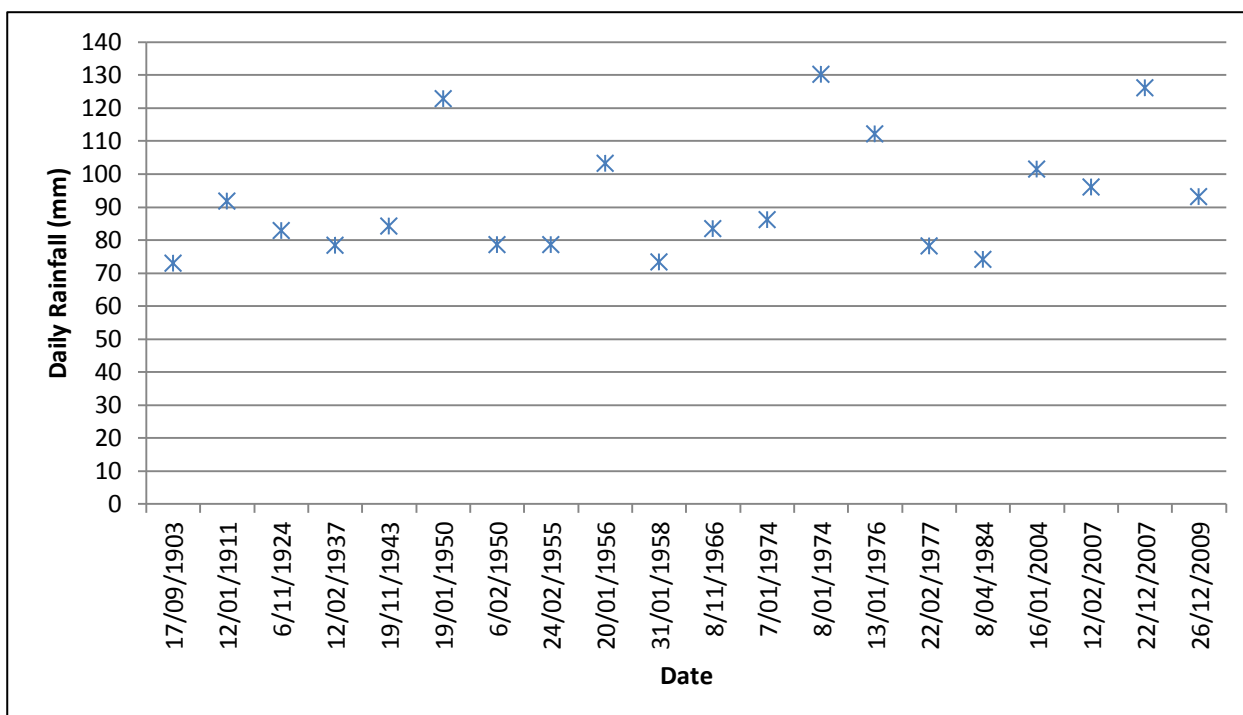

2.2.4 Streamflow Data

A review of PINNEENA version 9.3 (a surface water database released by NSW DPI Water) shows that a discontinued streamflow gauge (GS 421061) was located on Merri Merri Creek downstream of Sandy Camp Road crossing (refer to **Figure 1-1**). The gauge was in operation for the period 1984 to 1993. Limited information is available in PINNEENA on the quality of the data.

2.3 Community Consultation

2.3.1 Flood Questionnaire

A community consultation process was initiated to obtain flood information for past events. This involved sending a newsletter and a questionnaire (refer to **Appendix A**) to residents and landowners within the study area. The newsletter introduced the floodplain management process to the residents of the village, described the purpose of the questionnaire and provided the residents with contacts for their responses. The questionnaire was prepared in consultation with Council to help identify flooding issues for the study area and to provide reliable flood information to assist in the validation of the hydrologic and hydraulic computer models.

The flood information that was requested included:

- General information, such as:
 - Residents from the Study Area
 - Ownership of the residence
 - How long residents lived at the property
- Specific flood information, such as:
 - Experience on flooding in residence and/or at work
 - Location and depth of flood water in the worst flood experienced
 - Duration of flooding
 - Flood damages to residence and business
 - Disruption to vehicular access to residence during flooding
 - Assistance required by residents from SES
 - Flooding to residence made worse by works on other properties or by construction of roads or other structures
 - Identify information (eg. flood photographs, newspaper clippings, flood marks etc) that can be provided to Consultants
 - Residents intention for further development on their lands
 - Ranking of development types for protection against flooding
 - Ranking of potential flood mitigation measures
 - Any comments on any other issues associated with this study.

2.3.2 Summary of Responses to Flood Questionnaire

In total, three (3) responses were received from the community to the questionnaire. A summary of responses is provided in the following paragraphs.

Residency status (Question 1)

Two respondents were residents of the study area and one respondent was living outside the study area.

Length of Residency in Quambone and Business Activity (Questions 2-4)

One responded lived in the study area for one year and another respondent managed a business in the study area for seventeen (17) years.

Experiences of Flooding (Questions 5-12)

One respondent experienced flooding in the property in 2010, which caused major damages to garden, lawn and backyard and the duration of flooding was longer than three days and access to the property was cut off.

Another respondent experienced flooding in the property located outside the study area. Flooding cut off access to the property, damaged a car (\$2,000) and residents of the property required assistance from the SES during the flood.

Flood Affects to properties due to works (Questions 13 - 14)

One respondent located outside the study area identified that the public road aggravated flooding to the property.

Intention of Respondents for further development (Question 15)

One respondent was expecting to undertake minor extensions to the property.

Priority for protecting different types of developments from flooding (Question 16)

Respondents were asked to rank different types of development for protection against flooding. One respondent gave the highest priority for protection of residences against flooding.

Priority for flood mitigation measures (Question 17)

Maintaining an emergency flood free access was given the highest priority by two respondents and one respondent gave the highest priority to providing flood warning.

Willingness to provide additional information (Question 18)

Respondents did not provide additional information.

Contact details for respondents (Question 19)

Two respondents provided their contact details.

2.4 Topographic Survey

Very limited topographic data was available for Quambone to undertake this study. A LiDAR (Light Detection And Ranging) survey supplemented with ground survey was considered to be the most feasible option of collecting the required topographic data for this flood study. All topographic data available to this study will be provided to Council after completion of the flood study.

2.4.1 LiDAR Survey

Fugro Spatial Solutions Pty Ltd was engaged by Council to provide topographic survey data based on a LiDAR survey of the study area and accordingly, the LiDAR survey was undertaken on 21 March 2014. Fugro provided 1m square, 2m square and 10m square grid data and 0.5m contour data for the ground surface. The full LiDAR point cloud was classified to Level 3 according to LPI requirements. The spatial horizontal accuracy of the LiDAR data was 0.19m @ 67% CI and the vertical accuracy of the LiDAR data was 0.09m @ 67% CI.

A Digital Elevation Model (DEM) was created using the 1m square grid data provided by Fugro and is shown in **Figure 2-5**.

2.4.2 Ground Survey





The scope of the ground survey was identified by Jacobs, with Council engaging Geolyse Pty Ltd to undertake the ground survey. Geolyse provided the following results from the ground survey to Jacobs:

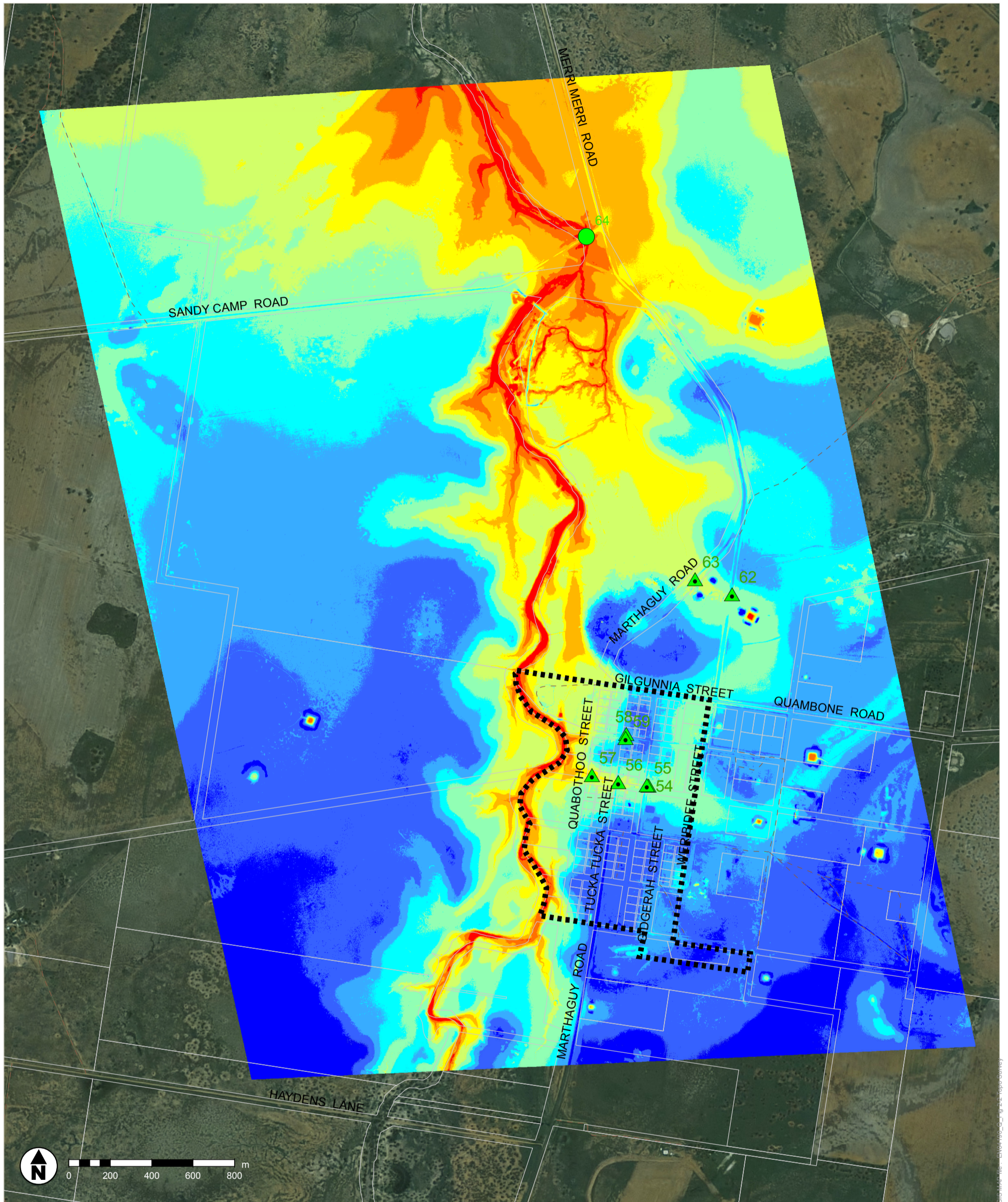



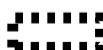





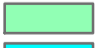

- Details (eg. size, shape, invert level, top of road level etc) for 8 culverts; and
- Details for 1 bridge along Sandy Camp Road.

Location of the above features is shown in **Figure 2-5** and details on the ground survey results are provided in **Appendix B**.

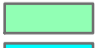

Legend

-  Study Area
-  Cadastre
-  Surveyed Culvert
-  Surveyed Bridge

LiDAR Data		
Elevation (mAHD)		
	147.7 - 149.7	
	149.8 - 150.5	
	150.6 - 151.2	
		
		
		
		
		
		
		

Data Sources: LPI, Council.

COPYRIGHT: The concepts and information contained in this document are the intellectual property of Jacobs. Use or copying of the document in whole or in part without written permission of Jacobs constitutes an infringement of copyright.

SCALE	A3		
SHEET	1 of 1	GDA 1994 MGA Zone 55	
TITLE	Extent of LiDAR Survey		
PROJECT	Flood Study for Quabone		
CLIENT	Coonamble Shire Council		
DRAWN	PROJECT #	MAP #	REV VER
AH	IA013100	FIGURE 2-5	2 1
CHECK	DATE		
AH	8/02/2016		

3. Catchment Hydrology

3.1 Sources of Flooding

Merri Merri Creek runs along the western boundary of the study area and is expected to be the main source of flooding for the study area. Both the Macquarie River and Marthaguy Creek may influence flooding in the study area to some extent. However, on the basis of the flood behaviour shown in **Figure 2-3** for the 1955 flood, the influence of both Marthaguy Creek and the Macquarie River is expected to be minimal. Hence, the focus of this study was flooding in the study area due to flooding in Merri Merri Creek.

3.2 Catchment Description

The study area is located in the Castlereagh River catchment, which is part of the Murray Darling Basin in central-western NSW. Merri Merri Creek is the waterway adjacent to the village of Quambone, which originates about 15km south of Gulargambone. The Creek then flows northwest towards Quambone. Back Creek is a major tributary of Merri Merri Creek, with the confluence being located about 10km south of Quambone. The Creek then flows in a northerly direction past Quambone and continues north-northwest joining Marthaguy Creek and eventually flowing into the Castlereagh River. Merri Merri Creek, at the village of Quambone, drains a catchment area of approximately 1,330km². The average slope of the catchment is approximately 0.1%.

The general land use within the catchment area of Merri Merri Creek upstream of Quambone is rural/natural. Sparse trees are present along creek lines, becoming more prominent downstream towards Quambone where a well-defined channel forms. The majority of the floodplain is covered by Poplar Box and Coolibah open woodland or is open grassland, cleared for grazing.

3.3 Estimation of Design Discharges

No recorded streamflow data for Merri Merri Creek or its tributaries were available to this study for the purpose of design flood estimation. Moreover, the method recommended in Australian Rainfall & Runoff (IEAust, 2001) for estimation of peak discharges for Western NSW is applicable to catchments up to 250 km² only. Hence, it was necessary to develop a rainfall runoff model to estimate design discharges for Merri Merri Creek and for a range of flood events for use in this study. The following sections describe details on the methodology adopted in the estimation of design discharges.

3.3.1 Selection of the Rainfall Runoff Model

The runoff routing model that was selected for this study is the RORB model version 6.18 (Laurenson et al 2010). RORB is one of the most widely used models of its type in Australia, and consequently there is substantial information available on the value of the model parameters for a wide range of catchments. The model has the capability to simulate both linear and non-linear catchment behaviour, and exhibits many desirable modelling features, such as areally distributed inputs, flexible reservoir-routing options and the ability to model flows at a number of points throughout the catchment.

3.3.2 Configuration of the RORB Model

The best available topographic data for the Merri Merri Creek catchment available to this study was 10m contour data and the LiDAR data. Combined with a GIS layer of watercourses and satellite imagery, sub-areas for the RORB model were delineated. The sub-areas within the RORB model were defined to coincide with watershed boundaries and stream junctions. The resulting sub-areas of the RORB model are shown in **Appendix C**.

The RORB model consisted of 17 nodes and 16 links. Out of the 17 nodes, 13 represent sub-catchments, 3 were stream junctions and the remaining one was the outlet. At the catchment scale, the proportion of imperviousness represented by houses and roads were considered negligible and therefore was not included in the model. All links were defined as natural channel type. Sub-areas for the RORB model and channel lengths were measured in MapInfo using the MiRORB tool.

3.3.3 Input Data for Design Flood Estimation

Rainfall Depths

The rainfall design data necessary for this study was generated from the Bureau of Meteorology's website (BoM 2014). The derivation of the rainfall intensity, frequency and duration (IFD) relationship within RORB was based on data presented in **Table 3-1**.

Table 3-1 Data used to estimate rainfall IFD

Parameter	Value
Zone	2
1 hour 2 year ARI (mm/hr)	27.57
12 hour 2 year ARI (mm/hr)	4.49
72 hour 2 year ARI (mm/hr)	1.20
1 hour 50 year ARI (mm/hr)	57.47
12 hour 50 year ARI (mm/hr)	9.02
72 hour 50 year ARI (mm/hr)	2.40
Skewness G	0.24
Geographical factor 2 year ARI F2	4.32
Geographical factor 50 year ARI F50	15.63

Areal Reduction Factors

Areal reduction factors (ARF) were applied based on the Siriwardena and Weinmann formulation (IEAust 2013) for the NSW GTSMR region. These factors were applied to events up to, and including, the 0.5% AEP event. The adopted ARF for the 1% AEP event was 0.82 corresponding to the 18 hour storm and the ARF from AR&R 1987 for the 18 hour storm for 1,000 km² catchment is approximately 0.9.

Temporal Patterns

Temporal patterns for all events storm durations up to, and including, the 0.5% AEP event were sourced using the 'filtered' pattern approach contained in RORB.

Initial and Continuing Rain Losses

Initial losses were varied based upon the AEP of the event. These losses were based on the research conducted by Walsh (1991). Continuing losses were set to the recommended 2.5mm/h for all events. A summary of the losses used can be seen in **Table 3-2**.

Table 3-2 Adopted initial and continuing losses

	5% AEP	1% AEP	0.5% AEP
Initial loss (mm)	25	15	15
Continuing loss (mm/hr)	2.5	2.5	2.5

k_c and m Parameters

A fixed value of 0.8 was adopted for m . This is the recommended value to use provided there is minimal information about catchment behaviour or gauge data to calibrate against (Laurenson et al, 2010). It is a common practice to estimate the value of k_c using Kleemola (1987) for ungauged catchments located in eastern NSW and Lipp (1983) for catchments located in western NSW. Kleemola (1987) gives a $k_c = 33.4$ and Lipp (1983) gives $k_c = 100$ (approximately) for the catchment area of Merri Merri Creek. The catchment area of Merri Merri Creek lies between the regions where the relationships for the estimation of k_c values were developed by Kleemola (1987) and Lipp (1983). In this study Pearse et. al. (2002) (i.e. $k_c = 1.14 \times D_{av}$) was used to estimate the value of k_c . Pearse et. al. (2002) gives $k_c = 61$ which lies between Kleemola (1987) and Lipp (1983) estimates and the adopted value of k_c is considered a reasonably sound estimate.

3.4 Design Discharges

The 18 hour storm produced peak discharges for 0.5%, 1% and 5% AEP events and the estimated peak discharges at the model outlet were 1,200 m³/s, 834 m³/s and 280 m³/s, respectively. Adequate data to undertake at-site flood frequency analysis is not available. Moreover, the catchment area of interest to this study is greater than 250 km² and, hence, the Probabilistic Rational Method of Australian Rainfall & Runoff (AR&R 2001) may not provide a reasonable basis for validation of design discharges estimated in this study. Moreover, the catchment area of interest to this study is located west of the published C10 values in AR&R.

4. Hydraulic Modelling

4.1 Approach

Whilst the hydrologic model RORB estimated rainfall-runoff generated from catchment areas of Merri Merri Creek at Quambone village, a hydraulic model is required to translate the rainfall-runoff into water levels and velocities which are critical elements in defining the flood risk.

4.2 The Hydrodynamic Modelling Software

The hydrodynamic model selected for use in this study is the Danish Hydraulic Institute's MIKE11 modelling system. MIKE11 is a one-dimensional, finite difference modelling system for rivers and floodplains using the full Saint Venant Equations of momentum and continuity for unsteady flow. The modelling system allows flow to occur in one-dimensional flowpaths (must be identified by the modeller), which can be linked in a network to represent quasi two-dimensional flow behaviour experienced on floodplains. It has the ability to model hydraulic structures, weirs and floodplain storages. MIKE11 has been extensively used in flood studies and floodplain management studies in Australia and overseas for the last 25 years.

MIKE11 has the following data requirements:

- Topographic data: as channel and floodplain cross sections;
- Bed resistance for cross sections;
- Obstructions to flow: details of hydraulic structures such as levees, culverts, bridges and weirs;
- Inflows to the model at appropriate locations; and
- Downstream boundary conditions in the form of water levels or stage-discharge rating curves.

The first step in developing a MIKE11 model involves schematising the floodplain into discrete topological elements. Important topological elements are stream channels, floodplains and hydraulic structures including bridges, culverts, weirs, levees, causeways, etc. These elements are usually represented by cross sections orthogonal to the direction of flow.

The second step in constructing a MIKE11 model is to designate links between each of the topologic elements. The links indicate the direction of flow assigned in the model and show the inter-connected network of flowpaths.

The third step involves transforming the topologic data into hydraulic parameters for use in the solution of the momentum and continuity equations. This includes vertical integration of cross sectional area, hydraulic radius, width and bed resistance.

In the fourth step, hydrologic inputs such as inflows and outflows to the model are defined. Generally, inflows are defined by inflow hydrographs whereas, outflows are defined by water level hydrographs or stage-discharge rating curves (a curve that shows relationship between flood flows and flood levels at a specified location in a stream channel).

In the fifth step, the model is run to simulate flooding conditions for the selected flood events. If adequate data is available the model is calibrated and once the model is calibrated, the performance of the model is validated against flood events not used in model calibration.

4.3 Model Formulation

4.3.1 Schematisation

Details on the topographic data available for this study are discussed in Section 2.4. A digital terrain model (DTM) was created using the 1m DEM provided by Fugro. The DTM was used to identify the main flow path along Merri Merri Creek through the study area. A flood runner of Merri Merri Creek runs parallel to the creek

along the eastern boundary of the study area and joins the creek upstream of Sandy Camp Road. The flood runner traverses longer distance than the creek and hence a single flow path was used to represent both the creek and the flood runner. A 5.3 km reach of Merri Merri Creek and its associated floodplain in Quambone village was selected for representation in the MIKE11 model. Eighteen (18) cross sections were cut from the DTM to represent Merri Merri Creek and its associated floodplain in the MIKE11 model. It is to be noted that Merri Merri Creek was dry when the LiDAR data was captured.

Significant hydraulic controls on Merri Merri Creek include the bridge crossing on Sandy Camp Road and an earthen dam located approximately 450m upstream of the bridge. At the time of undertaking this study, a section of the earthen dam on the main channel of Merri Merri Creek was found breached (refer to **Figure 4-1**) and hence the dam was not represented in the MIKE11 model. The bridge crossing on Sandy Camp Road was represented in the MIKE11 model. Details on the MIKE11 model schematic are shown in **Appendix D**.

- **Figure 4-1 Breached earthen dam across Merri Merri Creek**



4.3.2 Manning's 'n'

Bed resistance in the MIKE11 model was defined in terms of Manning's n using information collected from a range of sources including a site reconnaissance, photographs captured by the surveyors, available literature etc. Typical Manning's n values adopted for the various surfaces are given in **Table 4-1**.

■ Table 4-1 Adopted Manning's n Values

Surface	Manning's n
Main Channel of Merri Merri Creek	0.05
Road Surface	0.015 – 0.02
Floodplain (light brush)	0.05
Floodplain (medium brush)	0.07
Floodplain (dense brush)	0.10

4.3.3 Boundary Conditions

Considering the large catchment area of Merri Merri Creek at Quambone village and the small floodplain being modelled, steady inflows were used in the MIKE11 model for the 0.5%, 1% and 5% AEP events. An extreme event, being 3 times the peak flow in the 1% AEP event, was also modelled.

A stage-discharge relationship was defined to represent the downstream boundary of the MIKE11 model. The stage-discharge relationship was calculated within MIKE11 at cross section "MAIN_CK 6270" (approximately 650m of Sandy Camp Road Bridge) assuming a constant friction slope of 0.001 and a Manning's n of 0.05. The adopted stage-discharge relationship is presented in **Figure 4-2**.

■ Figure 4-2 Downstream stage-discharge relationship

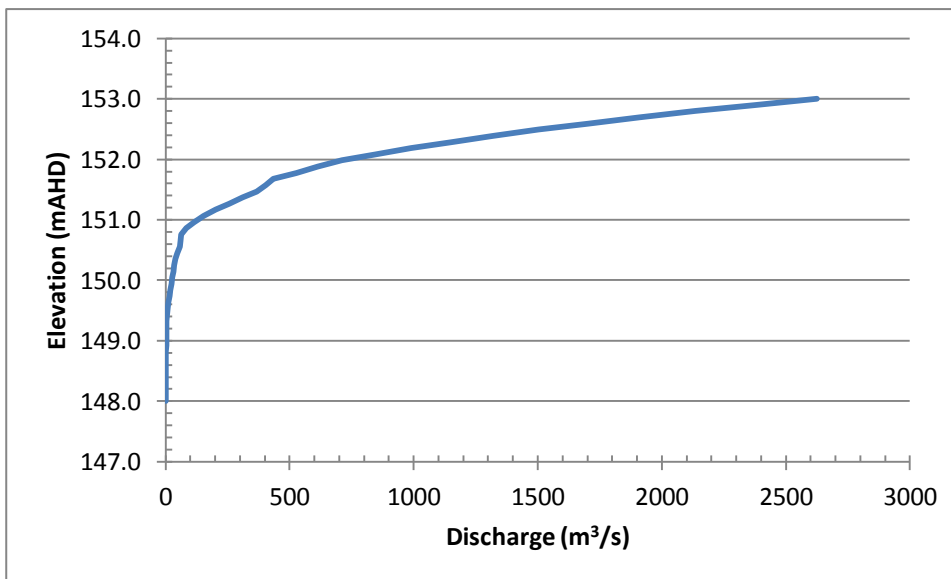

4.4 Flood Behaviour

The MIKE11 model was run for the 0.5%, 1%, 5% AEP events and an extreme flood event. Peak water levels, discharge and velocities are presented in **Appendix D**. Peak water level profiles along Merri Merri Creek are shown in **Figure 4-3**. Following observations can be made from **Figure 4-3**:

- Variation in peak water level profiles along Merri Merri Creek within the study area is consistent for all design flood events;
- The depth of flooding in Merri Merri Creek along the study area varies between 3.2m and 3.8m in the 5% AEP event and the peak water levels for the 1% AEP event are generally 1m higher than 5% AEP peak water levels;
- The difference in peak water levels in Merri Merri Creek along the study area for the 0.5% AEP and 1% AEP is approximately 0.3m; and

- The flood profile for the PMF event is, generally 0.7m to 1.0m above the flood profile for the 0.5% AEP event. It is to be noted that MIKE11 cross sections used for the PMF event were extended based on engineering judgement to avoid any potential glass walling effect.

■ Figure 4-3 Peak Water Level Profiles along Merri Merri Creek

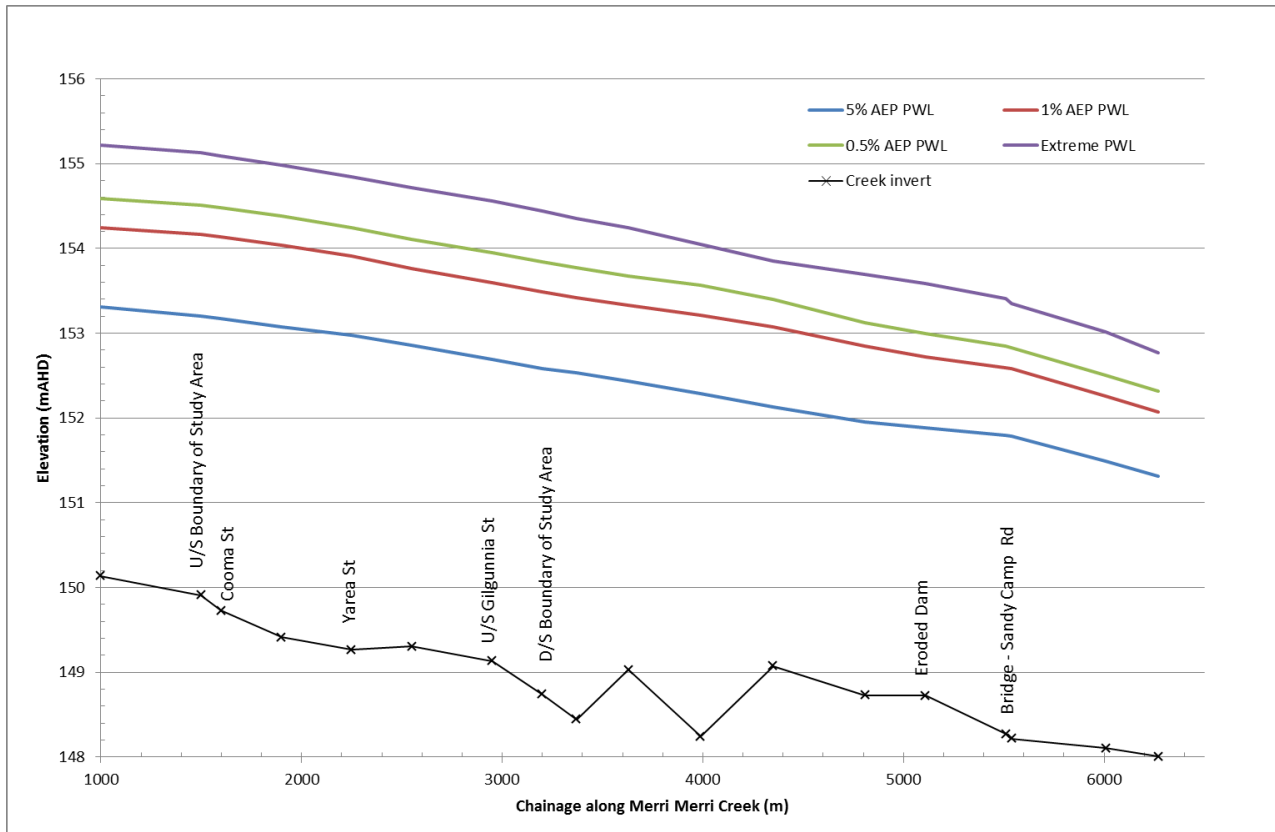

Peak velocities (averaged over the flow cross section) in Merri Merri Creek for all modelled design events are generally less than 1.2m/s as shown in **Appendix D**.

4.5 Sensitivity Analysis

A sensitivity analysis was undertaken to assess changes in peak water levels for the 1% AEP event due to changes in the adopted downstream boundary conditions and Manning's n values. A sensitivity analysis was also undertaken to assess the impact of the dam on peak water levels in Merri Merri Creek in the 1% AEP event assuming existence of the dam wall. Changes in the 1% AEP peak water levels due to the sensitivity analysis are shown in **Appendix D**.

The sensitivity of the 1% AEP peak water level profile on the adopted downstream boundary condition was assessed by lowering and raising the downstream boundary condition by 0.5m. Results from the sensitivity analysis indicated that peak water levels in Merri Merri Creek along the boundary of the study area were insensitive to the variation in the adopted downstream boundary condition.

The sensitivity of peak water levels to adopted Manning's n values was assessed by changing Manning's n values by 20%. An analysis of model results indicated a change in 1% AEP peak water levels up to 0.2m at the majority of cross sections.

If the earthen dam did not erode, it would increase 1% AEP peak water levels within the study area by up to 0.1m.

4.6 Flood Extent Mapping

The modelled peak water levels for the 1% AEP event and 1% AEP event plus 0.5m freeboard at MIKE11 model cross sections were used to create a flood surface for each event which was then intersected with the DTM representing the ground surface to delineate the flood extent for that event. The flood mapping was undertaken using the available routines in ArcMap. Almost the entire study area is flooded in the 1% AEP event as shown in **Figure 4-4** and in the 1% AEP event plus 0.5m free board the entire study area is inundated with floodwaters and hence SES needs to consider appropriate location for flood shelters outside the study area.

4.7 Mapping of Hazard and Hydraulic Categories

The MIKE11 modelling results for the 1% AEP event were used in ArcMap to delineate the flood hazard areas for the study area based on the hydraulic hazard category diagram presented in the *Floodplain Development Manual* (DECC, 2005), shown in **Figure 4-5**. The resulting high and low flood hazard areas for the 1% AEP event are shown in **Figure 4-6**. It is to be noted that high hazard areas results from either the depth of flooding is 1m or greater or the product of flood depth and velocity equal to or greater than 1. The flood extent for the 5% AEP event is also shown in **Figure 4-6** which indicates that the flood extent for the 5% AEP event is similar to the identified high flood hazard areas for the 1% AEP event.

The delineation of hydraulic categories is important with the adoption of merit based flood policy. This is because the NSW Government's Floodplain Development Manual (2005) recognises three hydraulic categories of flood prone land (floodway, flood fringe and flood storage). Definition of floodways, flood storage and flood fringe, as given in the Manual, are presented below:

- Floodways are those areas where a significant volume of water flows during floods and are often aligned with obvious natural channels. They are areas that, even if only partially blocked, would cause a significant increase in flood levels and/or a significant redistribution of flood flow, which may in turn adversely affect other areas. They are often, but not necessarily, areas with deeper flows or areas where higher velocities occur. However, the Floodplain Development Manual (2005) does not identify a standard technique for defining the floodway.
- Flood Storage areas are those parts of the floodplain that are important for the temporary storage of floodwaters during the passage of a flood.
- Flood fringe is the remaining area of land affected by flooding, after floodway and flood storage areas have been defined. Development in flood fringe areas would not have any significant effect on the pattern of flood flows and/or flood levels.

There is no technical definition of hydraulic categorisation and different approaches are used by different consultants and authorities. After reviewing the nature of riverine flooding in the study area and considering the definition of floodways in the Floodplain Development Manual, it is recommended that the high hazard areas for the 1% AEP event be classified provisionally as floodway (refer to **Figure 4-6**) and the remaining areas of the study area be classified as flood fringe. It is further recommended that the provisional hazard categories be based on hazard categories shown in **Figure 4-6**. There are a number of isolated areas which are identified as high hazard areas in **Figure 4-6** which will require further investigations if the flood categorisation for the areas are to be reviewed in the future.

Note: Flood extents outside the study area are indicative only



Legend

- Study Area
- Cadastre
- 1% AEP Flood
- 1% AEP + 0.5m freeboard
- MIKE11 Cross Section

Data Sources: LPI, Council.

LIMITATIONS: This mapping is based on data and assumptions identified in the Quambone Flood Study Report (2016) prepared by Jacobs. Jacobs does not warrant, guarantee or make representations regarding the currency and accuracy of information contained in this map.

SCALE	A3		
SHEET	1 of 1	GDA 1994 MGA Zone 55	
TITLE	Modelled Flood Extents		
PROJECT	Flood Study for Quambone		
CLIENT	Coonamble Shire Council		
DRAWN	PROJECT #	MAP #	REV VER
AH	IA013100	FIGURE 4-4	2 1
CHECK	DATE		
AH	8/02/2016		



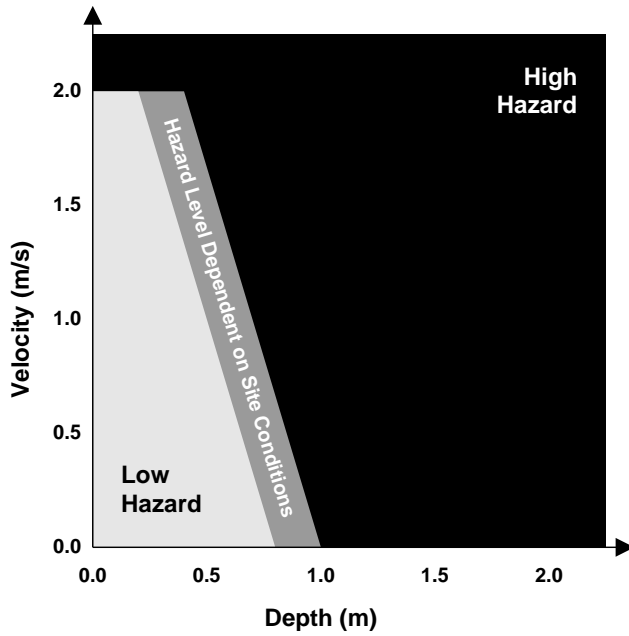

- Figure 4-5 Hydraulic Hazard Category Diagram (reproduced from Figure 6-1 in *NSW Floodplain Development Manual*)

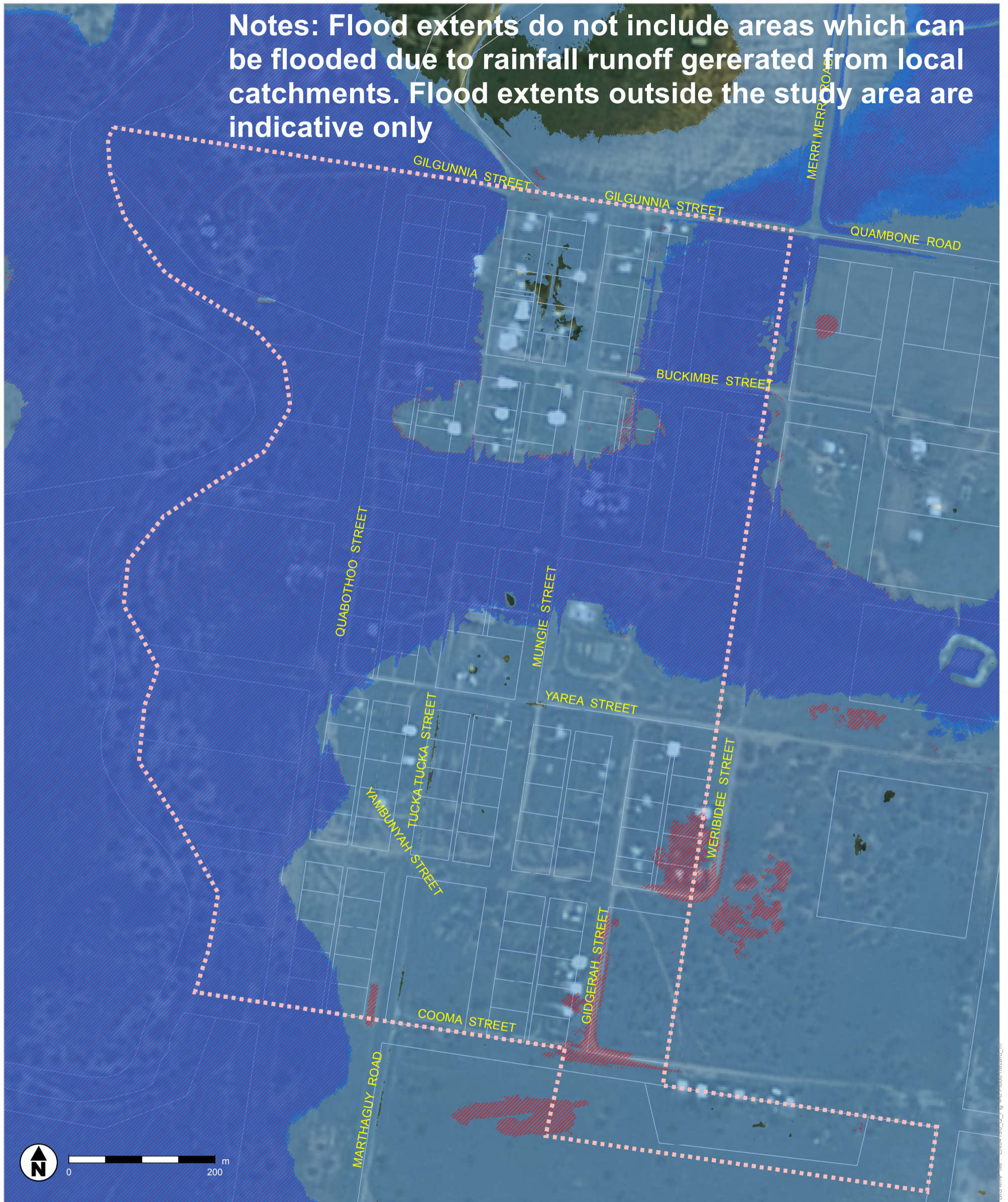

Notes: Flood extents do not include areas which can be flooded due to rainfall runoff generated from local catchments. Flood extents outside the study area are indicative only



Legend

-  Study Area
-  Cadastre
-  Low Hazard (1% AEP)
-  High Hazard (1% AEP)
-  5% AEP Flood Extent

Data Sources: LPI, Council.

LIMITATIONS: This mapping is based on data and assumptions identified in the Quambone Flood Study Report (2016) prepared by Jacobs. Jacobs does not warrant, guarantee or make representations regarding the currency and accuracy of information contained in this map.

SCALE	A3		
SHEET	1 of 1	GDA 1994 MGA Zone 55	
TITLE	Provisional 1% AEP Flood Hazard		
PROJECT	Flood Study for Quambone		
CLIENT	Coonamble Shire Council		
DRAWN	PROJECT #	MAP #	REV VER
AH	IA013100	FIGURE 4-6	2 1
CHECK	DATE		
AH	8/02/2016		

5. Conclusions and Recommendations

In accordance with NSW Government Policy, Coonamble Shire Council is responsible for managing flood risk within its local government area, which includes the Village of Quambone. This report documents the first two stages of the process of preparing the Floodplain Risk Management Plan – that is, the preparation of a Flood Study. In addition, this Study recommends development controls which Council could adopt to manage flood risk until the Plan is prepared.

5.1 Conclusions

A community consultation process was undertaken to collect information on flooding from the community. Information provided by the community identified loss of access to property during flooding as a major issue for the village of Quambone. Providing flood warning was also identified as a major issue for the village.

LiDAR and ground surveys were undertaken to capture the required topographic data for this flood study. The topographic data was used in the development of a hydrologic model and a hydraulic computer model. Both models were used to assess flood behaviour in the study area for the 0.5%, 1% and 5% AEP events and an extreme flood event (i.e. 3 times 1% AEP event).

Modelled peak water levels for the 1% and 5% AEP events and 1% AEP event with 0.5m freeboard were utilised to create flood extent maps. The flood map shows that the study area is cut-off from neighbouring towns in the 5% AEP event and the entire study area is subject to flooding in the 1% AEP event. This means that the study area is not suitable for locating flood evacuation centres.

A provisional hydraulic flood hazard map was prepared for the 1% AEP event, which shows that the extent of the hydraulic high hazard area in the 1% AEP events is similar to the flood extent for the 5% AEP event.

5.2 Recommendations

The scope of the study did not include undertaking an encroachment assessment to define the floodway and to provide detailed information to satisfy the requirements of the SES. It is recommended that Council undertakes these tasks at the Floodplain Risk Management Study stage.

The following recommendations are made for consideration by Council to manage flood risk for the study area until a Floodplain Risk Management Plan is adopted by Council:

- Council adopts this Flood Study and updates the local flood policy;
- The 1% AEP peak water level with 0.5m freeboard be adopted as the Flood Planning Level (FPL) for the study area;
- Council to erect flood signage along sections of main roads which are located within the provisional high hazard areas for the 1% AEP event;
- No developments/re-developments be permitted within provisional high hazard areas for the 1% AEP event and Council to implement a porous fencing policy for all boundary fencing located within the provisional high hazard areas for the 1% AEP event;
- Council to consider voluntary purchase of all habitable buildings located within the provisional high hazard areas for the 1% AEP event;
- Council to consider voluntary house raising or flood proofing for all habitable buildings which are located within the study area and outside the provisional high hazard areas for the 1% AEP event;
- New developments/ redevelopments to use flood compatible building materials which can withstand the flood depth and velocity of flood waters and floor levels of buildings are be located, at least, at the FPL;
- Council, SES and the Bureau of Meteorology to work in collaboration to provide a robust flood warning system for the village

- SES and Council to update the flood intelligence and evacuation plan on the basis of this report and communicate this to the community; and
- Council and SES to monitor future floods and capture photographs with a date stamp.

6. Acknowledgements

This study was undertaken by Jacobs on behalf of Coonamble Shire Council. Coonamble Shire Council has prepared this document with financial assistance from the NSW Government through its Floodplain Management Program. This document does not necessarily represent the opinions of the NSW Government or the Office of Environment and Heritage.

A number of organisations and individuals have contributed both time and valuable information to this study. The assistance of the following in providing data and/or guidance to the study is gratefully acknowledged:

- Residents of the study area
- Coonamble Shire Council
- Office of Environment and Heritage

7. References

- BoM 2014, 'Intensity-Frequency-Duration', Bureau of Meteorology, accessed 15 September 2014, <<http://www.bom.gov.au/hydro/has/cdirswebx/cdirswebx.shtml>>
- IEAust 2001, 'Australian Rainfall and Runoff: A guide to flood estimation' Vol. 1 and Vol. 2, Institute of Engineers Australia.
- IEAust 2013, 'Revision Project 2: Collection and review of areal reduction factors', Australian Rainfall and Runoff, Institute of Engineers Australia.
- Kleemola, S. (1987) Estimation of a runoff routing parameter from catchment characteristics for eastern New South Wales. Thesis (M.Eng.Sc), University of New South Wales.
- Laurenson, EM, Mein, RG, Nathan, RJ (2010). 'RORB Version 6 Runoff Routing Program User Manual', Monash University Department of Civil Engineering and Sinclair Knight Merz, January 2010.
- Lipp, W. R.(1983) Drainage design in remote areas – the Sturt Highway experience. NAASRA BEC 1983 Seminar : Waterway Analysis and Design. Aust. Road Research Board, pp. 124-139.
- Pearse, M., Jordan, P., Collins, Y. (2002), A simple method for estimating RORB model parameters for ungauged rural catchments, 27th IEAust Hydrology and Water Resources Symposium, Melbourne, 2002
- Walsh, MA, Pilgrim, DH and Cordery, I 1991, 'Initial losses for design flood estimation in New South Wales', *International Hydrology & Water Resources Symposium*, Perth.

8. Glossary

Annual Exceedance Probability (AEP)	The chance of a flood of a given or larger size occurring in any one year, usually expressed as a percentage.
Australian Height Datum (AHD)	A common national surface level datum approximately corresponding to mean sea level.
Average Annual Damage (AAD)	Depending on its size (or severity), each flood will cause a different amount of flood damage to a flood prone area. AAD is the average damage per year that would occur in a nominated development situation from flooding over a very long period of time.
Average Recurrence Interval (ARI)	The long-term average number of years between the occurrences of a flood as big as or larger than the selected event. For example, floods with a discharge as great as or greater than the 20 year ARI flood event will occur on average once every 20 years. ARI is another way of expressing the likelihood of occurrence of a flood event.
Catchment	The land area draining through the main stream, as well as tributary streams, to a particular site. It always relates to an area above a specific location.
Development	<p>Is defined in Part 4 of the EP&A Act</p> <p><u>In fill development</u>: refers to the development of vacant blocks of land that are generally surrounded by developed properties and is permissible under the current zoning of the land. Conditions such as minimum floor levels may be imposed on infill development.</p> <p>New development: refers to development of a completely different nature to that associated with the former land use. Eg. The urban subdivision of an area previously used for rural purposes. New developments involve re-zoning and typically require major extensions of exiting urban services, such as roads, water supply, sewerage and electric power.</p> <p>Redevelopment: refers to rebuilding in an area. Eg. As urban areas age, it may become necessary to demolish and reconstruct buildings on a relatively large scale. Redevelopment generally does not require either re-zoning or major extensions to urban services.</p>
Effective Warning Time	The time available after receiving advise of an impending flood and before the floodwaters prevent appropriate flood response actions being undertaken. The effective warning time is typically used to move farm equipment, move stock, raise furniture, evacuate people and transport their possessions.
Flood	Relatively high stream flow which overtops the natural or artificial banks in any part of a stream, river, estuary, lake or dam, and/or local overland flooding associated with major drainage before entering a watercourse, and/or coastal inundation resulting from super-elevated sea levels and/or waves overtopping coastline defences excluding tsunami.

Flood fringe areas	The remaining area of flood prone land after floodway and flood storage areas have been defined.
Flood liable land	Is synonymous with flood prone land (i.e.) land susceptibility to flooding by the PMF event. Note that the term flooding liable land covers the whole floodplain, not just that part below the FPL (see flood planning area)
Floodplain	Area of land which is subject to inundation by floods up to and including the probable maximum flood event, that is flood prone land.
Floodplain risk management options	The measures that might be feasible for the management of particular area of the floodplain. Preparation of a floodplain risk management plan requires a detailed evaluation of floodplain risk management options.
Floodplain risk management plan	A management plan developed in accordance with the principles and guidelines in this manual. Usually include both written and diagrammatic information describing how particular areas of flood prone land are to be used and managed to achieve defines objectives.
Flood plan (local)	A sub-plan of a disaster plan that deals specifically with flooding. They can exist at state, division and local levels. Local flood plans are prepared under the leadership of the SES.
Flood planning levels (FPLs)	Are the combination of flood levels (derived from significant historical flood events or floods of specific AEPs) and freeboards selected for floodplain risk management purposes, as determined in management studies and incorporated in management plans. FPLs supersede the "designated flood" or the "flood standard" used in earlier studies.
Flood proofing	A combination of measures incorporated in the design, construction and alteration of individual buildings and structures subject to flooding, to reduce or eliminate flood damages.
Flood readiness	Readiness is an ability to react within the effective warning time.
Flood risk	<p>Potential danger to personal safety and potential damage to property resulting from flooding. The degree of risk varies with circumstances across the full range of floods. Flood risk in this manual is divided into 3 types, existing, future and continuing risks. They are described below.</p> <p><u>Existing flood risk</u>: the risk a community is exposed to as a result of its location on the floodplain.</p> <p><u>Future flood risk</u>: the risk a community may be exposed to as a result of new development on the floodplain.</p> <p><u>Continuing flood risk</u>: the risk a community is exposed to after floodplain risk management measures have been implemented. For a town protected by levees, the continuing flood risk is the consequences of the levees being overtopped. For an area without any floodplain risk management measures, the continuing flood risk is simply the existence of its flood exposure.</p>

Flood storage areas	Those parts of the floodplain that are important for the temporary storage of floodwaters during passage of a flood. The extent and behaviour of flood storage areas may change with flood severity, and loss of flood storage can increase the severity of flood impacts by reducing natural flood attenuation. Hence, it is necessary to investigate a range of flood sizes before defining flood storage areas
Floodway areas	Those areas of the floodplain where a significant discharge of water occurs during floods. They are often aligned with naturally defined channels. Floodways are areas that, even if only partially blocked, would cause a significant redistribution of flood flow, or a significant increase in flood levels.
Freeboard	Provides reasonable certainty that the risk exposure selected in deciding on a particular flood chosen as the basis for the FPL is actually provided. It is a factor of safety typically used in relation to the setting of floor levels, levee crest levels, etc. Freeboard is included in the flood planning level.
Hazard	A source of potential harm or situation with a potential to cause loss. In relation to this manual the hazard is flooding which has the potential to cause damage to the community.
Local overland flooding	Inundation by local runoff rather than overbank discharge from a stream, river, estuary, lake or dam.
m AHD	Metres Australian Height Datum (AHD)
m/s	Metres per second. Unit used to describe the velocity of floodwaters.
m ³ /s	Cubic metres per second or "cumec". A unit of measurement of creek or river flows or discharges. It is the rate of flow of water measured in terms of volume per unit time.
Mainstream flooding	Inundation of normally dry land occurring when water overflows the natural or artificial banks of a stream, river, estuary, lake or dam.
MIKE11	A computer program used for analysing behaviour of unsteady flow in open channels and floodplains.
Modification measures	Measures that modify either the flood, the property or the response to flooding.
Overland flowpath	The path that floodwaters can follow as they are conveyed towards the main flow channel or if they leave the confines of the main flow channel. Overland flowpaths can occur through private property or along roads.
Probable Maximum Flood (PMF)	The largest flood that could conceivably occur at a particular location, usually estimated from probable maximum precipitation coupled with the worst flood producing catchment conditions. Generally, it is not physically or economically possible to provide complete protection against this event. The PMF defines the extent of flood prone land, that is, the floodplain.

Risk	Chance of something happening that will have an impact. It is measured in terms of consequences and likelihood. In the context of the manual it is the likelihood of consequences arising from the interaction of floods, communities and the environment.
RORB	RORB is a general runoff and streamflow routing computer program used to calculate flood hydrographs from rainfall and other channel inputs.
Runoff	The amount of rainfall which actually ends up as a streamflow, also known as rainfall excess.
Stage	The amount of rainfall which actually ends up as streamflow, also known as rainfall excess.

Appendix A. Questionnaire



Flood Study for Quambone - Questionnaire

Coonamble Shire Council has contracted the Consultant, Sinclair Knight Merz (SKM), to undertake a flood study for the village of Quambone. The flood study area for Quambone is shown in the attached Map 1.

The objective of this study is to define the riverine as well as overland flooding behaviour within the study area. The study will produce information on flood levels, velocities and flows for a range of flood events under existing catchment conditions. Outcomes from the study would assist Council to apply appropriate development controls as a management measure in the floodplain risk management process, as it is believed to be most feasible management option for Council's consideration at this stage.

The Consultant would like to receive feedback from the community on a number of issues and topics already highlighted by the Council with regard to flooding in the study area.

If you cannot answer any question in the questionnaire, or do not wish to answer a question, then leave it unanswered and proceed to the next question. **Your input to this important study will be greatly appreciated.** If you need additional space, please add sheets.

Please send your response to this questionnaire directly to the Consultant **before 28 June 2013** at the address provided below.

Akhter Hossain
 P O Box 164
 St Leonards, NSW 1590
 or
 email: ahossain@globalskm.com

Place a tick or write a number in the relevant box as per instruction or write answers.

Question No.	Question and Answer
1.	<p>Do you live (reside) or have lived in the study area shown on Map 1?</p> <p>A <input type="checkbox"/> Yes (Please provide your address and put an 'X' on the relevant map) </p> <p>B <input type="checkbox"/> No (Go to Question 3)</p>
2.	<p>Do you own or rent your residence in the study area shown on Map 1?</p> <p>A <input type="checkbox"/> Own B <input type="checkbox"/> Rent C How long have you lived in the study area? (Please write number of years)..... ***If you are not sure whether you are in the map or not, please provide address</p>
3.	<p>Do you own or manage a business in the study area?</p> <p>A <input type="checkbox"/> Yes, For how many years?</p> <p>B <input type="checkbox"/> No (go to Question 5)</p>

Question No.	Question and Answer
4.	<p>What kind of business is yours?</p> <p>A <input type="checkbox"/> Home based business B <input type="checkbox"/> Shop/commercial premises C <input type="checkbox"/> Light industrial D <input type="checkbox"/> Heavy industry E <input type="checkbox"/> Others, please write type of business</p>
5.	<p>Have you had any experience of flooding (due to Merri Merri Creek and storm events as well) in and around where you live or work?</p> <p>A <input type="checkbox"/> Yes B <input type="checkbox"/> No (Go to Question 15)</p>
6.	<p>How deep was the floodwater (from Merri Merri Creek and storm water as well) in the worst flood/ storm event that you experienced? Please estimate the depth What was the year of this flood?..... Where was this flood? A <input type="checkbox"/> At your house? B <input type="checkbox"/> At work? C <input type="checkbox"/> Elsewhere? Please provide the street address for this flood?</p>
7.	<p>How long did the floodwaters stay up?</p> <p>A <input type="checkbox"/> Less than 6 hours B <input type="checkbox"/> Approximately 1 day C <input type="checkbox"/> More than 3 days</p>
8.	<p>What damage resulted from this flood in your residence? (Please indicate either "none", "minor", "moderate" or "major".)</p> <p>A <input type="checkbox"/> Damage to garden, lawns or backyard B <input type="checkbox"/> Damage to external house walls C <input type="checkbox"/> Damage to internal parts of house (floor, doors, walls etc) D <input type="checkbox"/> Damage to possessions (fridge, television etc) E <input type="checkbox"/> Damage to car F <input type="checkbox"/> Damage to garage G <input type="checkbox"/> Other damage, please list..... H <input type="checkbox"/> What was the cost of the repairs, if any?.....</p>
9.	<p>What damage resulted from this flood in your business? (Please indicate either "none", "minor", "moderate" or "major".)</p> <p>A <input type="checkbox"/> Damage to surroundings B <input type="checkbox"/> Damage to building C <input type="checkbox"/> Damage to stock D <input type="checkbox"/> Other damages, please list..... E <input type="checkbox"/> What was the cost of the repairs, if any?.....</p>
10.	<p>Was vehicle access to/from your property disrupted due to floodwaters during the worst flooding/ storm event?</p> <p>A <input type="checkbox"/> Not affected</p>

Question No.	Question and Answer
	B Minor disruption (roads flooded but still driveable) C <input type="checkbox"/> Access cut off
11.	Were you or members of your family required assistance from SES during flood events? A <input type="checkbox"/> No B Yes, Please specify how many times (in total) members of your family required assistance?
12.	What information can you provide on past floods/ storm events that created flooding? (You can tick more than one item). Please write any descriptions at the end of the questionnaire A <input type="checkbox"/> No information B <input type="checkbox"/> Information on extent or depth of floodwater at particular locations, newspaper clippings or other images on the past floods C <input type="checkbox"/> Any permanent marks indicating maximum flood level for particular floods D <input type="checkbox"/> Memory of flow directions, depth or velocities
13.	Do you consider that flooding of your property has been made worse by works on other properties, or by the construction of roads or other structures? A <input type="checkbox"/> Yes (please provide further details and attach extra pages if necessary. Please provide a sketch if possible). B <input type="checkbox"/> Unsure C <input type="checkbox"/> No
14.	Do you have any photographs of past floods that would be useful for the consultant to help him understand the area flooded or other flood effects and are you willing to provide copies? If possible please attach the photographs (with dates and location) which will be copied and returned. A <input type="checkbox"/> Yes (either attach or the consultant will contact you to arrange for a copy to be made and returned) B <input type="checkbox"/> No
15.	Do you expect to undertake any further development on your land in the future? A <input type="checkbox"/> No B <input type="checkbox"/> Minor extensions C <input type="checkbox"/> New building D <input type="checkbox"/> Unsure E <input type="checkbox"/> Other (please specify) _____
16.	Please rank the following development types according to what you consider should be assigned greatest priority in protecting from flooding (1 = greatest priority to 7 = least priority). Please identify specific items if necessary. A <input type="checkbox"/> Commercial B <input type="checkbox"/> Heritage items, please specify _____ C <input type="checkbox"/> Residential D <input type="checkbox"/> Community facilities (schools, halls, etc.) _____ E <input type="checkbox"/> Critical utilities (power substations, telephone exchanges, etc.) _____ F <input type="checkbox"/> Emergency facilities (Hospital, Police Station, etc.) _____ G <input type="checkbox"/> Recreation areas and facilities _____

Question No.	Question and Answer
17.	<p>Please rank the following by placing numbers from 1 to 6 (1 = greatest priority to 6 = least priority) next to A, B, C, D, E and F.</p> <p>A <input type="checkbox"/> Protecting residents/business from flooding B <input type="checkbox"/> Protecting land of residents/businesses from flooding C <input type="checkbox"/> Maintaining an emergency flood free access D <input type="checkbox"/> Providing flood signage for public safety E <input type="checkbox"/> Support from SES F <input type="checkbox"/> Providing flood warning</p>
18.	<p>Do you wish to comment on any other issues associated with this study? Please add comments at the end of the questionnaire or please indicate your willingness to answer questions over the phone?</p> <p>_____</p> <p>_____</p> <p>_____</p> <p>_____</p>
19.	<p>Do you wish to remain on the mailing list for further details, Newsletters etc?</p> <p>A <input type="checkbox"/> Yes (please provide contact details, see next question) B <input type="checkbox"/> No</p>
20.	<p>If you would like, please provide details of where you live and how we can contact you if we need to follow up on some details or seek additional comment.</p> <p>Name: _____</p> <p>Address: _____</p> <p>_____</p> <p>Telephone:</p> <p>Fax:</p> <p>Email:.....</p>
	<p>Space for additional comments</p> <p>_____</p> <p>_____</p> <p>_____</p> <p>_____</p> <p>_____</p> <p>_____</p> <p>_____</p> <p>_____</p> <p>_____</p> <p>_____</p> <p>_____</p>

Map 1 – Study Area for Quambone

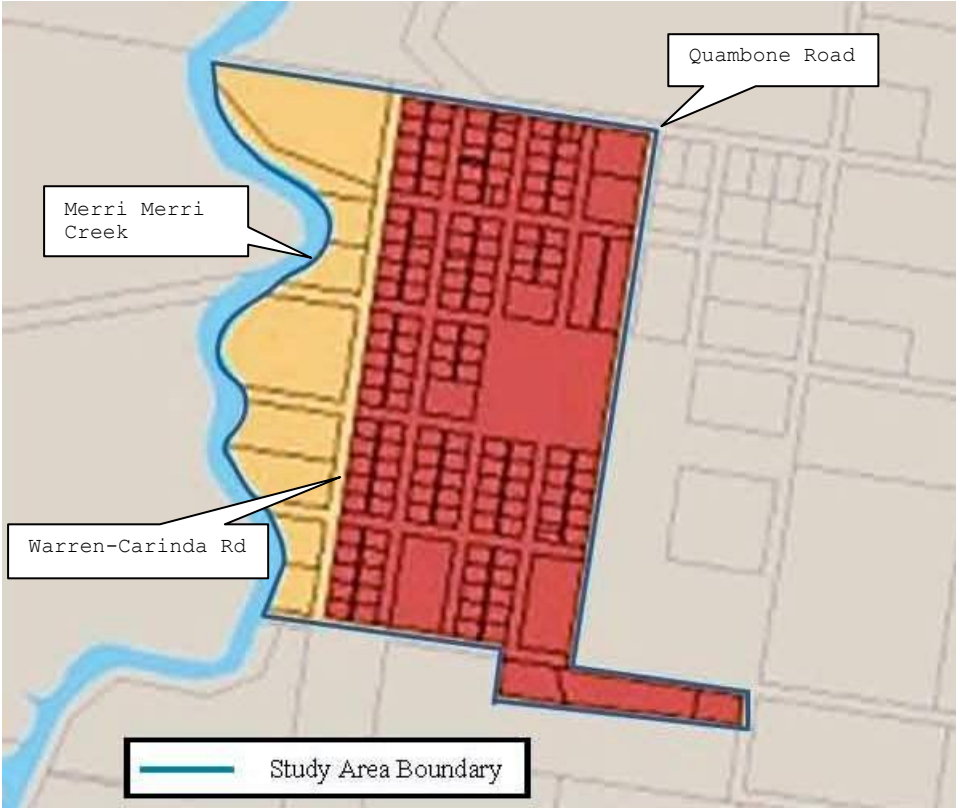

Appendix B. Topographic Survey

FLOOD STUDY SURVEY, WEST COONAMBLE, GULARGAMBONE & QUAMBONE

PREPARED FOR:

SINCLAIR KNIGHT MERZ

APRIL 2014



POSTAL ADDRESS PO Box 1963
LOCATION 154 PEISLEY STREET
TELEPHONE 02 6393 5000
EMAIL ORANGE@GEOLYSE.COM

ORANGE NSW 2800
ORANGE NSW 2800
FACSIMILE 02 6393 5050
WEB SITE WWW.GEOLYSE.COM

TABLE OF CONTENTS

TABLES

TABLE 1 – CULVERTS.....	1
TABLE 2 – BRIDGES.....	4
TABLE 3 – FLOOD MARKERS.....	5

DRAWINGS

Concrete Bridges Pages 1 - 5

All Coordinates are MGA zone 55. All Elevations are AHD

ID	SKM ID	Inlet Easting	Inlet Northing	Outlet Easting	Outlet Northing	Type	Dimension	Number of Cells	Length	Inlet Invert Level (AHD)	Outlet Invert Level (AHD)	Blockage %	Inlet Photo	Outlet Photo
1	57	640014.66	6531853.30	640002.09	6531855.34	RCP	0.45Ø	1	12.70	225.73	225.62	0	7	8
2	56	639815.71	6531944.87	639808.22	6531946.15	RCP	0.45Ø	2	7.60	225.50	225.42	0	5	6
3	54	640983.89	6531990.58	640984.85	6531996.90	Box Conc.	0.6 X 1.2	4	6.40	221.21	221.21	0	9	10
4	41	No Structure											11	
5	55	See Bridges												
6	53	See Bridges												
7	59	639479.85	6532711.01	639480.23	6532715.16	RCP	0.375Ø	1	4.10	223.86	223.66	50	12	13
8	58	639611.63	6532872.33	639612.36	6532878.65	PVC Pipe	0.25Ø	1	6.30	223.20	222.99	60	14	15
9	29	629402.73	6561866.43	629395.48	6561864.51	Corrugated Metal Pipe	0.6Ø	9	7.50	190.56	190.56	0	103	
10	32	629258.77	6562400.38	629251.48	6562398.64	Corrugated Metal Pipe	0.6Ø	2	7.50	190.03	190.03	0	102	
11	31	629134.29	6562863.69	629126.95	6562861.96	Corrugated Metal Pipe	0.6Ø	3	7.50	190.20	190.15	0	101	100
12	30	628818.13	6564039.36	628810.81	6564037.74	Corrugated Metal Pipe	0.6Ø	3	7.50	188.46	188.46	0		99
13	26	628638.10	6565055.26	628630.62	6565055.73	Corrugated Metal Pipe	0.6Ø	4	7.50	187.08	187.08	0		98
14	1	628755.65	6565871.91	628748.63	6565873.15	Corrugated Metal Pipe	0.6Ø	4	7.50	186.02	186.00	5		97
15	25	628808.66	6566210.50	628803.73	6566211.28	Box Conc.	0.6 X 2.1	4	5.00	185.38	185.38	0		96
16	23	628867.78	6566568.56	628860.31	6566569.27	Corrugated Metal Pipe	0.75Ø	2	7.50	185.28	185.28	10		95
17	24	628900.40	6566786.38	628895.45	6566787.24	Box Conc.	0.6 X 2.1	4	5.00	185.28	185.28	0		94
18	21	628953.95	6567122.11	628949.01	6567122.88	Box Conc.	0.6 X 2.1	4	5.00	185.42	185.42	0		93
19	22	629006.43	6567439.42	628997.73	6567440.98	Corrugated Metal Pipe	0.75Ø	6	8.80	185.12	185.06	0	92	91
20	20	629089.55	6568004.37	629094.46	6568003.64	Box Conc.	0.45 X 2.1	2	4.90	185.21	185.17	0	70	69
21	19	629135.37	6568292.56	629140.29	6568291.74	Box Conc.	0.45 X 2.1	3	5.00	185.37	185.37	0	68	67
22	17	629605.48	6569581.41	629609.96	6569579.19	Box Conc.	0.45 X 2.1	2	5.00	182.73	182.71	0		66
23	18	629903.52	6570178.43	629908.00	6570176.20	Box Conc.	0.45 X 2.1	2	5.00	182.57?		0		71
24	16	630211.04	6570799.98	630217.62	6570796.37	Corrugated Metal Pipe	0.6Ø	4	7.50	180.95	180.95	0		65

All Coordinates are MGA zone 55. All Elevations are AHD

ID	SKM ID	Inlet Easting	Inlet Northing	Outlet Easting	Outlet Northing	Type	Dimension	Number of Cells	Length	Inlet Invert Level (AHD)	Outlet Invert Level (AHD)	Blockage %	Inlet Photo	Outlet Photo
25	15	630429.44	6571240.37	630436.13	6571237.00	Corrugated Metal Pipe	0.6Ø	4	7.50	180.62	180.62	0		104
26	14	630880.22	6572159.37	630884.94	6572157.69	Box Conc.	0.45 X 2.1	2	5.00	179.47	179.46	0	62	61
27	12	631056.56	6572770.26	631061.33	6572768.77	Box Conc.	0.45 X 2.1	7	5.00	178.40	178.39	0		58
28	34	631498.85	6573391.85			Box Conc.	0.6 X 2.1	3	5.00			0		104
29	11	No Structure												
30	8	631803.70	6574648.33	631794.20	6574649.02	Corrugated Metal Pipe	0.45Ø	5	9.50	178.32	178.25	0	27	28
31	2	No Structure												
32	27	630335.32	6570838.66	630338.78	6570848.41	RCP	0.45Ø	1	10.30	180.77	180.76	0	64	63
33	28	No Structure												
34	13	630957.87	6572199.50	630960.49	6572209.56	RCP	0.45Ø	1	10.40	179.40	179.32	5	60	59
35	33	No Structure												
36	35	631342.12	6573461.92	631331.41	6573465.89	Box Conc.	0.5 X 0.9	2	11.40	178.14	178.15	0	56	57
37	36	631319.39	6573512.93	631300.82	6573519.99	Box Conc.	0.45 X 0.9	2	19.80	178.21	178.09	0	54	55
38	37	631115.19	6573650.58	631104.50	6573656.94	RCP	0.45Ø	1	12.44	177.54	177.61	0	50	51
39	38	631146.67	6573702.58	631135.44	6573708.49	RCP	0.375Ø	1	12.60	177.80	177.67	0	52	53
40	43	626280.46	6572310.53	626275.00	6572322.03	RCP	0.525Ø	1	12.70	178.66	178.61	5	39	40
41	44	627802.91	6573056.42	627798.98	6573066.23	RCP	0.45Ø	1	10.57	176.48	176.39	0	41	42
42		628034.61	6573148.27	628028.94	6573162.05	RCP	0.45Ø	2	14.90	176.46	176.30	0	45	46
43	3	628065.36	6573160.29	628060.36	6573174.27	RCP	0.375Ø	1	14.80	176.39	176.30	0	43	44
44		628670.87	6573407.72	628667.02	6573416.99	Box Conc.	0.45 X 0.9	6	10.00	175.99	175.94	0	47	48
45		628993.53	6573538.37	628989.55	6573548.13	RCP	0.45Ø	2	10.50	175.68	175.57	0	37	38
46	4	629054.76	6573562.83	629050.88	6573572.49	RCP	0.45Ø	2	10.40	175.68	175.57	0	35	36
47	5	629418.28	6573699.14	629414.93	6573708.46	Box Conc.	0.45 X 2.15	1	9.90	175.81	175.74	0	33	34
48	39	630578.99	6574086.31	630576.71	6574096.53	RCP	0.45Ø	1	10.40	177.07	177.02	0	31	32
49	6	630832.04	6574133.32	630830.71	6574143.28	Box Conc.	0.5 X 0.9	6	10.00	177.27	177.13	20	29	30
50	9	631692.57	6574605.17	631680.26	6574606.64	Box Conc.	0.3 X 1.2	3	12.40	177.90	178.02	0	25	26

All Coordinates are MGA zone 55. All Elevations are AHD

ID	SKM ID	Inlet Easting	Inlet Northing	Outlet Easting	Outlet Northing	Type	Dimension	Number of Cells	Length	Inlet Invert Level (AHD)	Outlet Invert Level (AHD)	Blockage %	Inlet Photo	Outlet Photo
51	40	630572.07	6574841.89			Earth Channel				176.04			24	
52	10	631083.60	6574764.91			Earth Channel				175.92			23	
53	7	See Bridges												
54		583258.58	6577669.48	583253.56	6577670.20	RCP	0.45Ø	2	5.00	151.99	151.98	0	76	77
55	49	583250.65	6577670.50	583236.32	6577672.39	Box Conc.	0.35 X 1.2	1	14.40	151.93	151.92	0	74	75
56	50	583112.74	6577685.60	583101.45	6577687.41	RCP	0.45Ø	2	11.40	151.51	151.51	0	72	73
57	51	582984.95	6577719.11	582977.25	6577721.92	RCP	0.45Ø	1	8.20	151.05	150.96	50	78	79
58		583151.35	6577918.57	583131.36	6577921.57	RCP	0.375Ø	1	20.20	152.66	152.35	50	90	89
59		583148.66	6577897.73	583128.93	6577900.68	RCP	0.375Ø	1	19.90	152.70	152.54	50	87	88
60	52	No Structure												
61	48	No Structure												
62	47	583662.03	6578594.41	583649.78	6578596.29	RCP	0.45Ø	2	12.40	152.25	152.15	0	85	86
63	46	583484.28	6578667.31	583478.32	6578673.57	Round Conc. Half pipe	0.9Ø	1	8.60	151.87	151.84	0	80	10
64	45	See Bridges												

All Coordinates are MGA zone 55. All Elevations are AHD

ID	SKM ID	Easting	Northing	Deck Level (AHD)	Underside Level (AHD)	Length X Width	Inlet Photo	Outlet Photo
5	55	640285.59	6532934.57	224.80	224.00	87.2 X 9.3	19	20
6	53	639865.25	6533187.19	223.70	223.10	135 X 8	16	17
53	7	631199.12	6575430.03	179.84	179.59	20.3 X 7.8	21	22
64	45	582958.40	6580321.44	151.77	151.28	21.3 X 4.16	82	84
65	42	643879.46	6522416.94	242.11	241.28	195 X 10	1,2	3,4

All Coordinates are MGA zone 55. All Elevations are AHD

ID	Address	Description	Easting	Northing	Level (AHD)	Photo
1	13 Wilaga St, Gulargambone	Floor Level	639982.57	6532725.84	226.64	
2	25 Munnell St, Gulargambone	Floor Level	639910.47	6532440.99	226.40	
3	54 Munnell St, Gulargambone	Floor Level	639816.71	6532140.61	226.56	
4	5 & 7 Wilga St, Gulargambone	Floor Level	640029.05	6532724.59	226.37	
5	23 Munnell St, Gulargambone	Floor Level	639913.50	6532471.65	226.13	
6	7-19 Skuthorpe Lane, Gulargambone	Floor Level	639841.32	6532811.19	226.25	
7	21 Munnell St, Gulargambone	Floor Level Inaccessible				
8	76 Munnell St, Gulargambone	Floor Level	639708.03	6531777.58	227.13	
9	61 Munnell St, Gulargambone	Floor Level	639854.11	6532031.96	226.40	
10	63 Munnell St, Gulargambone	Floor Level	639852.36	6532002.22	225.95	
11	65 Munnell St, Gulargambone	Floor Level	639847.74	6531966.76	226.02	
12	2-6 Bourbah St, Gulargambone	Floor Level	640163.33	6532882.97	225.93	
13	4 Evelyn Simpson Ave, Gulargambone	Floor Level	639915.11	6532122.09	226.02	
14	31 Coonamble St, Gulargambone	No info				
15	Armitree St, Gulargambone	Church	639844.97	6532302.38	226.24	
16	Quambone - Gulargambone Road	Two Bolts in tree	639851.08	6533058.82	225.44 low bolt 225.84 High bolt	107
17	Quambone - Gulargambone Road Bridge	Stream gauge Zero Level	639855.24	6533184.26	219.46	18

All Coordinates are MGA zone 55. All Elevations are AHD

ID	Address	Description	Easting	Northing	Level (AHD)	Photo
18	89-95 Railway St, Coonamble					
19	Nebea Street	Flood mark destroyed by new levee bank				
20	21 Pages Tce, Coonamble	Floor Level	632112.84	6574968.71	181.13	
21	Eurimie Creek	Contact couldn't remember mark				
22	85-92 Railway St, Coonamble	Floor Level	631813.05	6573722.61	180.29	
23	"Riverside Cottage" Coonamble	Contact had marked on tree 5.2m and 4.5m Floods. Level recorded is of 5.2m mark. Contact commented on a significant increase of vegetation in the river and build up of sand over the last 6 years.	631360.37	6568344.46	186.74	108
24	"Woodland" Coonamble	No mark found				
25	"Hamilton" Coonamble	Contact Indicated a point on the ground where water regularly comes up to. Contact commented on a significant increase of vegetation in the river and build up of sand over the last 6 years.	632422.73	6571660.56	183.39	

Drawings



Pty Ltd
ACN 075 657 359

Surveying, Engineering, Town Planning
and Environmental Consultants

ID 65
CONCRETE BRIDGE

OUR REF : 214079
PAGE 1 OF 5 PAGES
DATE OF SURVEY: 9/4/2014

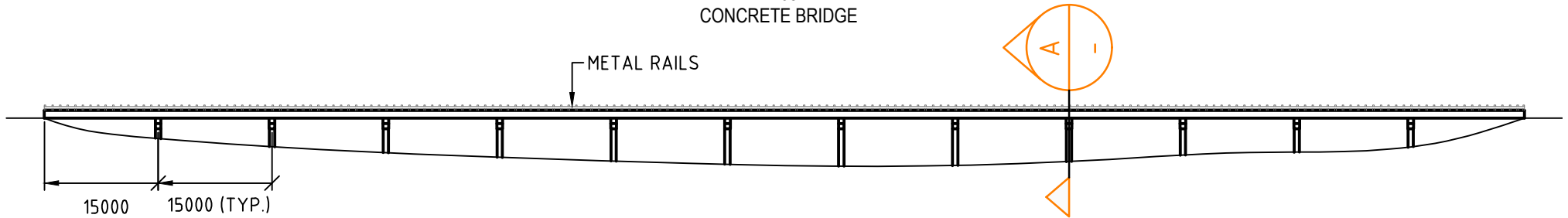

BRIDGE 65 - ELEVATION
NOT TO SCALE

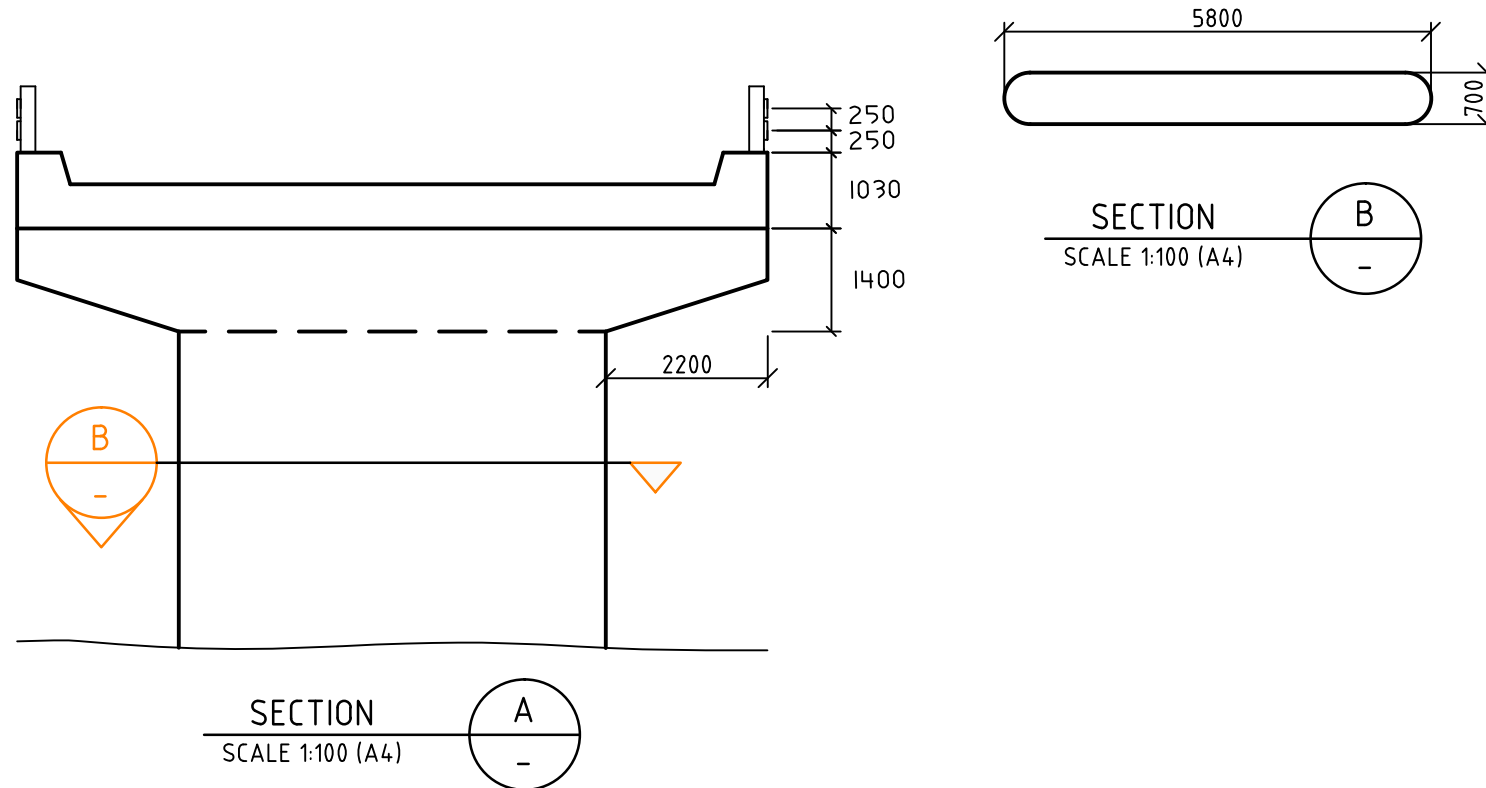



Pty Ltd
ACN 075 657 359

Surveying, Engineering, Town Planning
and Environmental Consultants

ID 5

CONCRETE BRIDGE

OUR REF : 214079
PAGE 2 OF 5 PAGES
DATE OF SURVEY: 9/4/2014

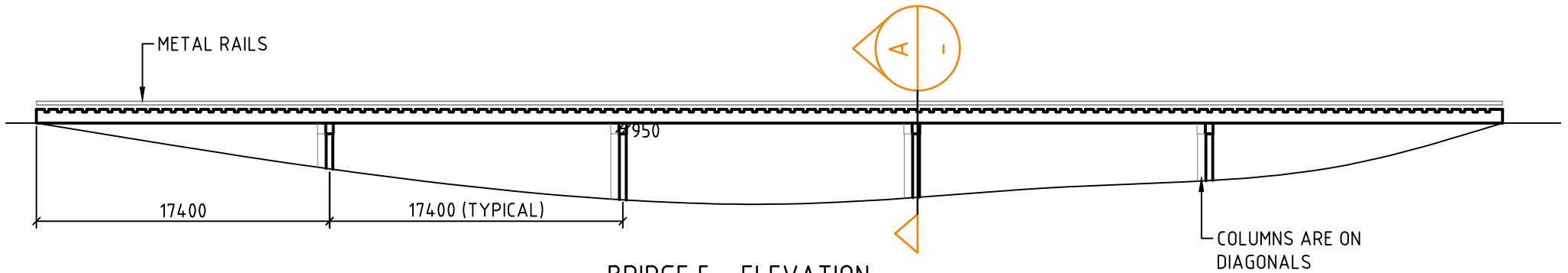

BRIDGE 5 - ELEVATION

NOT TO SCALE

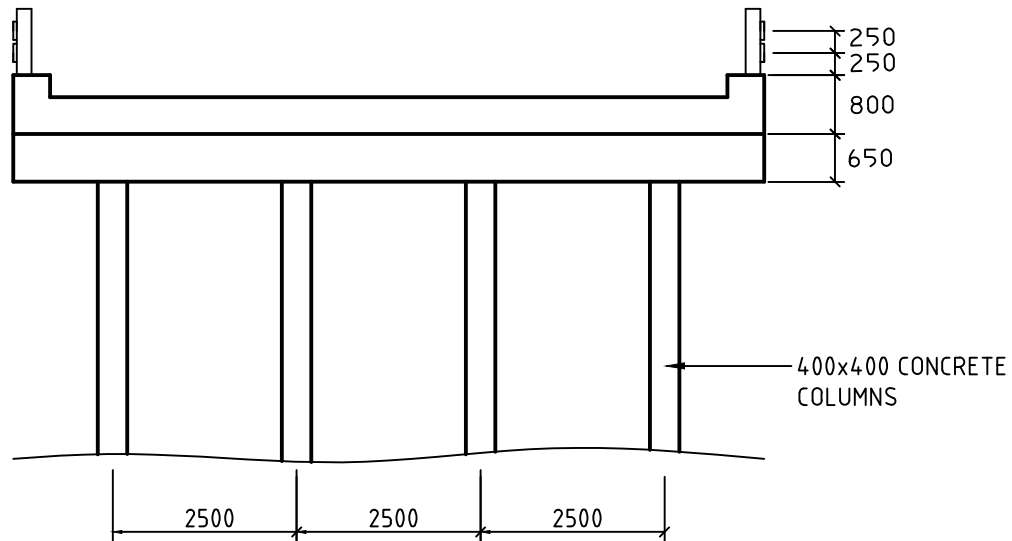

SECTION
SCALE 1:100 (A4)

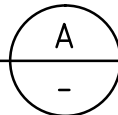



Pty Ltd
ACN 075 657 359

Surveying, Engineering, Town Planning
and Environmental Consultants

ID 53

CONCRETE BRIDGE

OUR REF : 214079
PAGE 3 OF 5 PAGES
DATE OF SURVEY: 9/4/2014

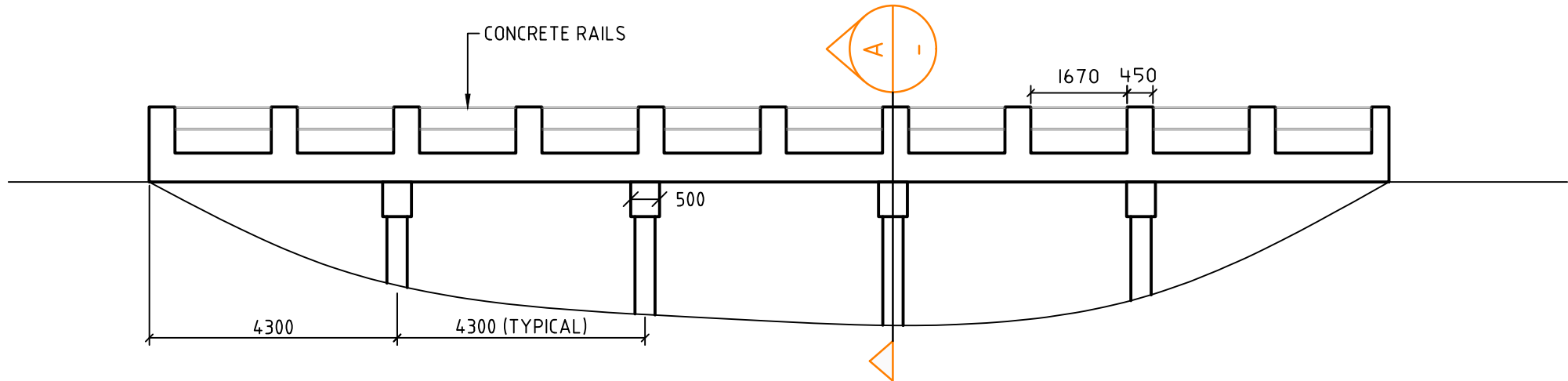

BRIDGE 53 - ELEVATION
NOT TO SCALE

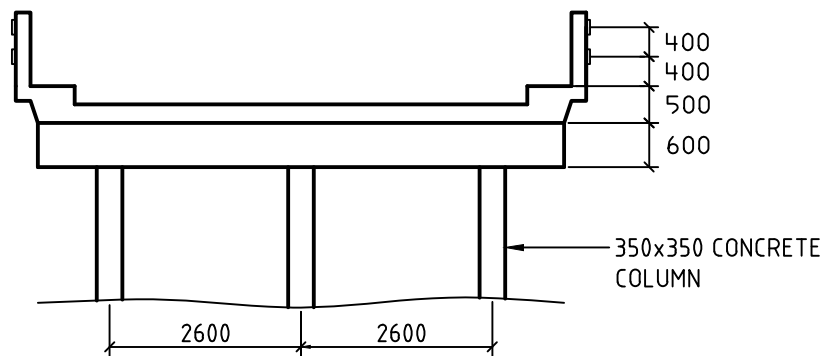

SECTION
SCALE 1:100 (A4)

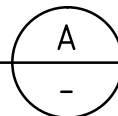



Pty Ltd
ACN 075 657 359

Surveying, Engineering, Town Planning
and Environmental Consultants

ID 6
CONCRETE BRIDGE

OUR REF : 214079
PAGE 4 OF 5 PAGES
DATE OF SURVEY: 9/4/2014

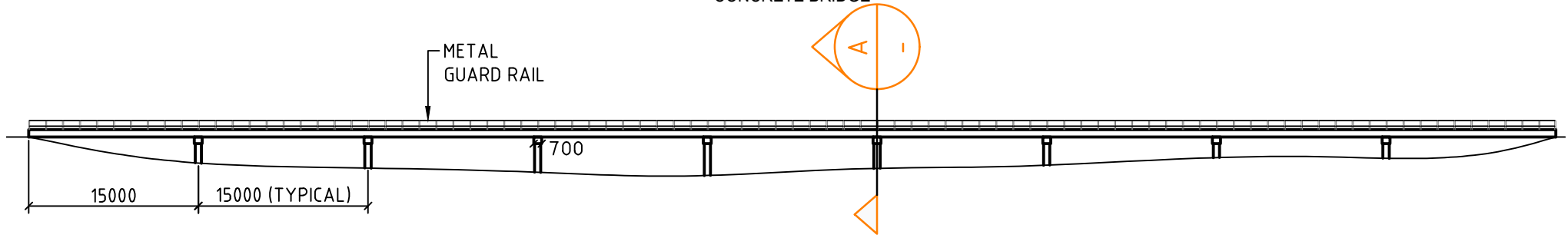

BRIDGE 6 - ELEVATION
NOT TO SCALE

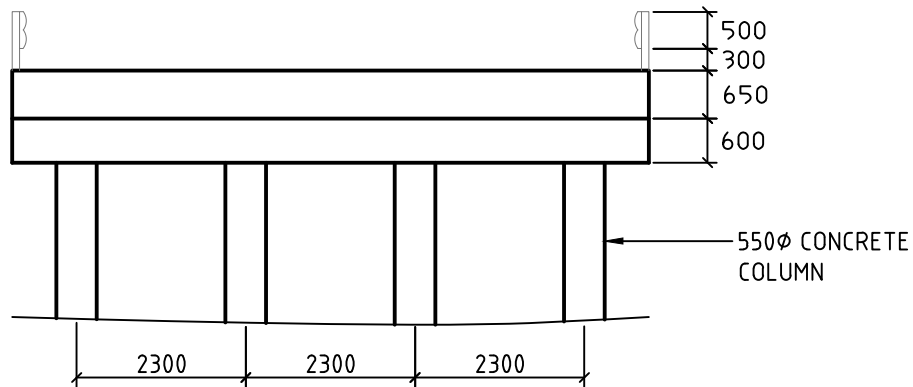

SECTION
SCALE 1:100 (A4)

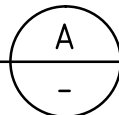



Pty Ltd
ACN 075 657 359

Surveying, Engineering, Town Planning
and Environmental Consultants

ID 64

CONCRETE BRIDGE

OUR REF : 214079
PAGE 5 OF 5 PAGES
DATE OF SURVEY: 09/04/2014

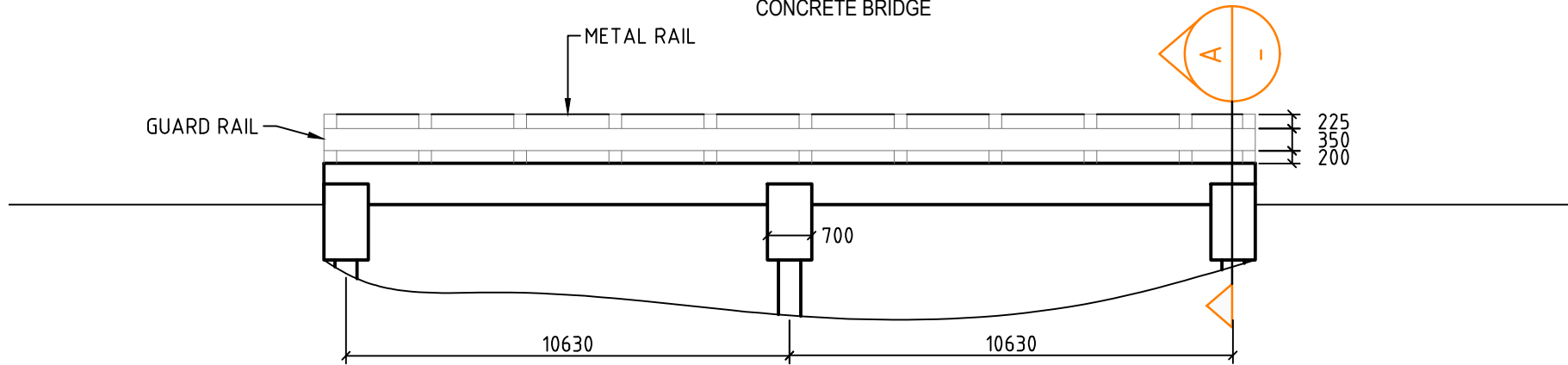

BRIDGE 64 - ELEVATION
NOT TO SCALE

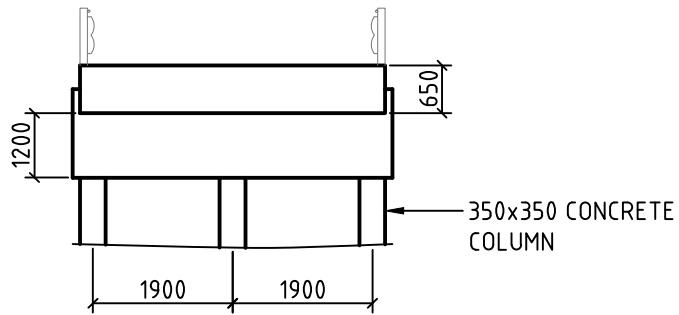

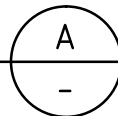

SECTION
SCALE 1:100 (A4)

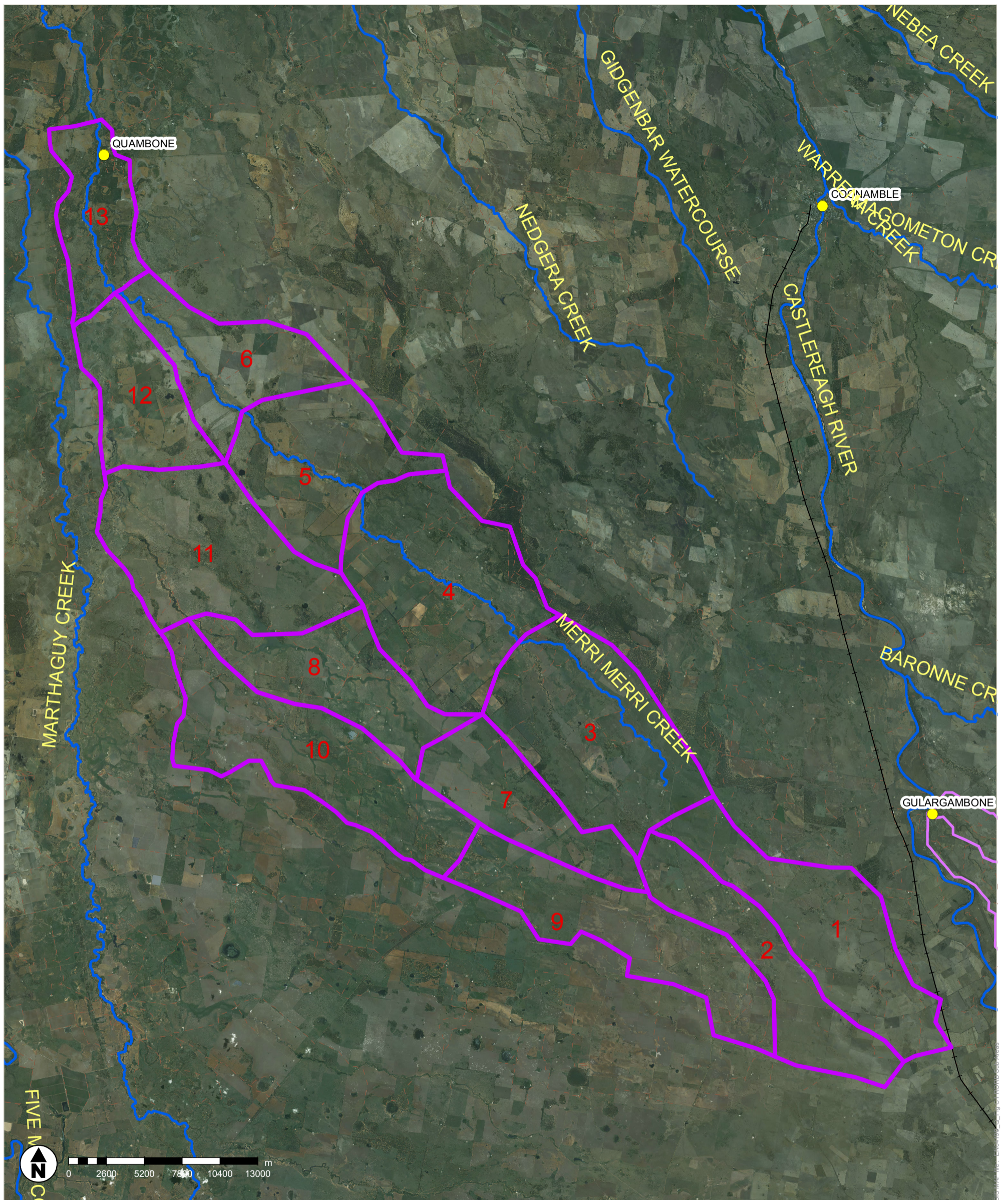

Appendix C. Hydrologic Modelling

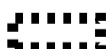
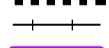

Legend

-  Study Area
-  Railway
-  RORB Subarea

Data Sources: LPI, Council.		SCALE		A3
SHEET		1 of 1	GDA 1994 MGA Zone 55	
TITLE Subareas of RORB Model				
PROJECT Flood Study for Quambone				
CLIENT Coonamble Shire Council				
DRAWN	PROJECT #	MAP #	REV	VER
AH	IA013100	FIGURE C-1	1	1
CHECK	DATE			
AH	4/11/2014			

COPYRIGHT: The concepts and information contained in this document are the intellectual property of Jacobs. Use or copying of the document in whole or in part without written permission of Jacobs constitutes an infringement of copyright.

Appendix D. Hydraulic Modelling

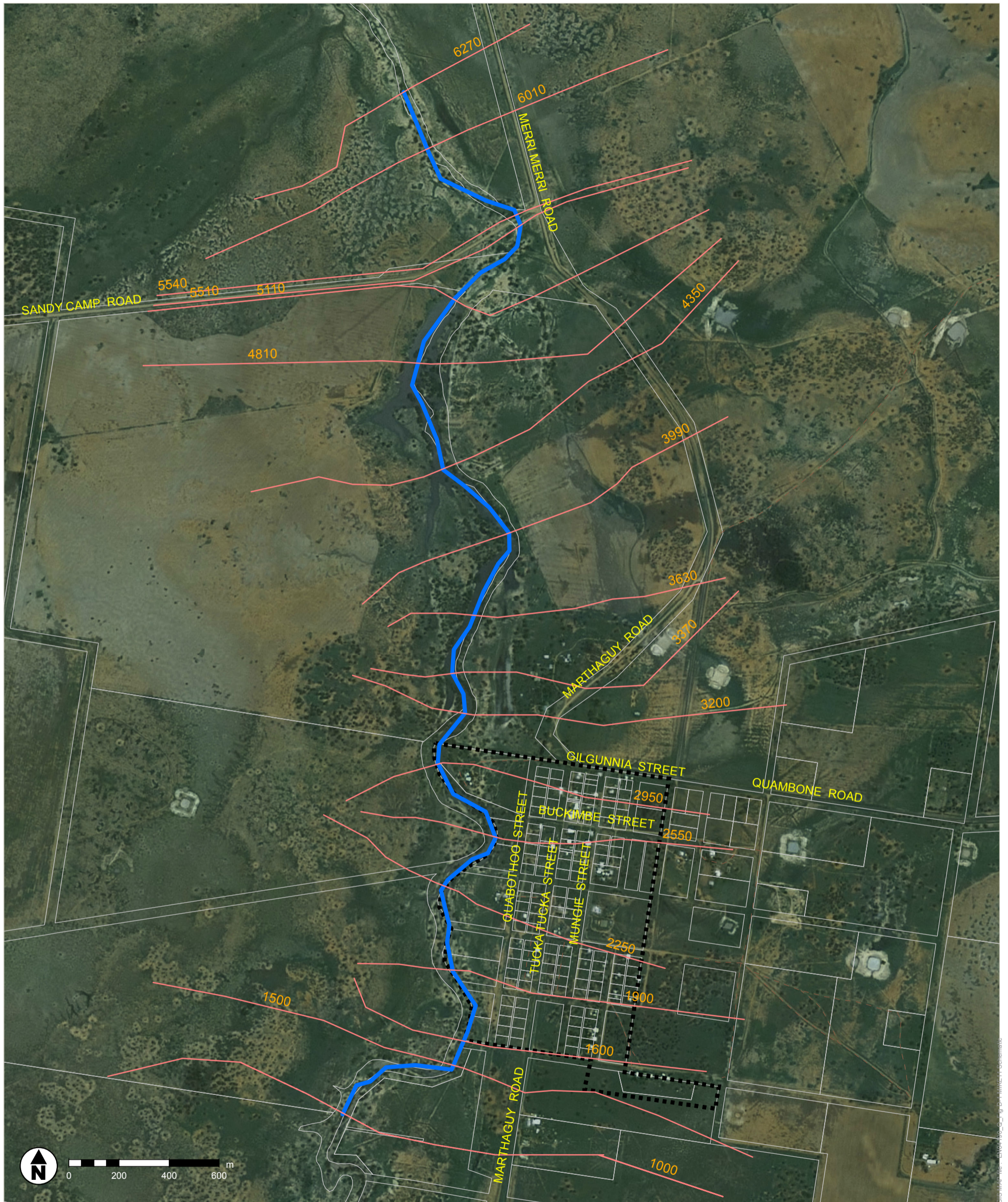

Legend

- Study Area
- Cadastre
- MIKE11 Cross Section
- MIKE11 Flowpath

Data Sources: LPI, Council.

COPYRIGHT : The concepts and information contained in this document are the intellectual property of Jacobs. Use or copying of the document in whole or in part without written permission of Jacobs constitutes an infringement of copyright.

SCALE	A3		
SHEET	1 of 1	GDA 1994 MGA Zone 55	
TITLE	MIKE11 Model Schematic		
PROJECT	Flood Study for Quambone		
CLIENT	Coonamble Shire Council		
DRAWN	PROJECT #	MAP #	REV VER
AH	IA013100	FIGURE D-1	1 1
CHECK	DATE		
AH	8/02/2016		

Table D-1 MIKE11 Modelling Results

Cross Section ¹ Chainage (m)	Invert (mAHD)	Peak Water Level (mAHD)				Peak Discharge (m ³ /s)				Peak Velocity (m/s)				Remarks
		5% AEP	1% AEP	0.5% AEP	Extreme ²	5% AEP	1% AEP	0.5% AEP	Extreme	5% AEP	1% AEP	0.5% AEP	Extreme	
1000	150.14	153.31	154.25	154.59	155.22	280	834	1,200	2,502	0.64	0.68	0.71	0.42	
1500	149.91	153.20	154.17	154.51	155.13	280	834	1,200	2,502	0.67	0.80	0.82	0.43	U/S Boundary of Study Area
1600	149.73	153.17	154.14	154.48	155.09	280	834	1,200	2,502	0.97	0.99	1.04	0.59	Cooma St
1900	149.42	153.08	154.04	154.38	154.99	280	834	1,200	2,502	0.63	1.02	1.05	0.52	
2250	149.26	152.98	153.91	154.25	154.85	280	834	1,200	2,502	0.78	1.04	1.03	0.63	Yarea St
2550	149.31	152.86	153.76	154.11	154.72	280	834	1,200	2,502	0.84	1.15	1.13	0.62	
2950	149.13	152.69	153.60	153.95	154.56	280	834	1,200	2,502	0.82	1.08	1.07	0.53	U/S Gilgunnia St
3200	148.74	152.59	153.49	153.85	154.44	280	834	1,200	2,502	0.70	0.95	0.91	0.66	D/S Boundary of Study Area
3370	148.45	152.53	153.42	153.77	154.36	280	834	1,200	2,502	0.69	0.91	0.99	0.63	
3630	149.03	152.44	153.33	153.68	154.25	280	834	1,200	2,502	0.61	0.76	0.85	0.60	
3990	148.24	152.29	153.21	153.57	154.05	280	834	1,200	2,502	0.66	0.72	0.75	0.74	
4350	149.07	152.13	153.07	153.40	153.86	280	834	1,200	2,502	0.55	0.67	0.75	0.75	
4810	148.73	151.96	152.85	153.12	153.70	280	834	1,200	2,502	0.46	0.58	0.65	0.55	
5110	148.72	151.89	152.72	153.00	153.59	280	834	1,200	2,502	0.37	0.45	0.53	0.48	Eroded Dam
5510	148.27	151.80	152.59	152.85	153.41	280	834	1,200	2,502	0.37	0.51	0.55	0.56	U/S Sandy Camp Road
5540	148.22	151.79	152.58	152.83	153.35	280	834	1,200	2,502	0.66	0.73	0.75	0.66	D/S Sandy Camp Road
6010	148.10	151.49	152.26	152.51	153.01	280	834	1,200	2,502	0.43	0.49	0.53	0.59	
6270	148.01	151.31	152.08	152.32	152.77	280	834	1,200	2,502	0.51	0.56	0.63	0.72	

¹Refer to Figure D-1 for location of cross sections

²3 x 1% AEP

Table D-2 Sensitivity of 1% AEP Peak Water Levels to Adopted Parameter Values

Cross Section ¹ Chainage (m)	Manning's n		Tailwater Level		With Dam	Remarks
	Increase	Decrease	Increase	Decrease		
1000	0.16	-0.18	0.00	0.00	0.08	
1500	0.16	-0.18	0.01	0.00	0.06	U/S Boundary of Study Area
1600	0.16	-0.19	0.01	0.00	0.05	Cooma St
1900	0.16	-0.19	0.01	0.00	0.06	
2250	0.16	-0.19	0.01	0.00	0.04	Yarea St
2550	0.16	-0.19	0.02	-0.01	0.06	
2950	0.17	-0.19	0.02	-0.01	0.09	U/S Gilgunnia St
3200	0.17	-0.19	0.03	-0.01	0.08	D/S Boundary of Study Area
3370	0.16	-0.19	0.03	-0.01	0.01	
3630	0.16	-0.18	0.04	-0.02	-0.04	
3990	0.16	-0.18	0.05	-0.02	-0.05	
4350	0.15	-0.17	0.06	-0.03	-0.07	
4810	0.12	-0.15	0.11	-0.05	-0.13	
5110	0.12	-0.13	0.15	-0.07	0.00	Eroded Dam
5510	0.10	-0.10	0.20	-0.09	0.00	U/S Sandy Camp Road
5540	0.10	-0.10	0.20	-0.09	0.00	D/S Sandy Camp Road
6010	0.06	-0.06	0.37	-0.27	0.00	
6270	0.00	0.00	0.50	-0.50	0.00	

¹Refer to Figure D-1 for location of cross sections